

PIOTR KRÓL, MACIEJ HENECZKOWSKI

Politechnika Rzeszowska, Wydział Chemiczny
Zakład Technologii Tworzyw Sztucznych
Aleja Powstańców Warszawy 6, 33-959 Rzeszów

Numerical simulation of polymerization processes of diisocyanates and diols

Summary — An experimentally verified kinetic model of stepwise polyaddition [9], involving a series of consecutive and parallel reactions, was used to simulate the reaction of diisocyanates with diols to yield linear polyurethanes. The underlying assumptions and the method to derive model equations are given; the technological interpretation of model parameters is described. Variation ranges of model parameters are given in relation to polymerization conditions (time, temperature, reactants mole ratio, substitution effects in diisocyanates). Oligomer fraction concentrations, functional group conversion degrees, and average M of polyurethanes at successive process stages were calculated by well-known numerical procedures. When suitably rearranged, the relationship obtained allows to see the effect of process conditions and monomer structure on the properties of polyurethanes in relation to the preparation method used. Author's own routine, *Reaktor*, run in *Windows 95*, saves the results as ASCII files which can be retrieved into other software (Excel, Origin) and further processed to yield 2-D or 3-D graphs. Simulation results are at any moment available as 2-D diagrams with reaction time as the independent variable.

Key words: polyaddition of diisocyanates to diols, linear polyurethanes, simulation routine *Reaktor* (*Windows '95*), model equations.

Advantages have been presented [1] which result from the use of mathematical methods in the planning of experiments and in the numerical simulation of polymerization processes. The former methods are continually improved to get optimum composition and optimum physical properties of plastics produced. However, the latter methods are recently becoming increasingly important. The Authors are placing special emphasis on polyurethane production processes.

This work presents practical application of the numerical simulation method which has been developed on the basis of the kinetic model of stepwise polyaddition of diisocyanates to polyols; the work illustrates new areas for use of mathematical models in polyurethane plastics manufacturing processes.

GENESIS OF THE POLYADDITION KINETIC MODEL

For better understanding, the theory of the simulation method developed is summarized. It is based on the kinetic modelling of the system of consecutive-and-parallel reactions which constitute stepwise polyaddition. A detailed description of the mathemat-

ical fundamentals has been reported elsewhere [2]. The model starts with adopting a specific kinetic scheme. This scheme must satisfy several conditions as a prerequisite to define unique model equations:

1. The polyurethane chain is assumed to result from the reactions of functional groups:



Side reactions are omitted. Depending on process conditions, side reactions of isocyanates can involve trimerization, allophanate crosslinking, reactions with water or formation of allophanate, urea and biuret type groupings. Moreover, the kinetic models usually disregard the possible effects of ring formation reactions, both intramolecular and intermolecular. It is convenient to use Monte-Carlo methods to model cyclization reactions [3]. In fact, reaction (1) represents a number of general reactions which can be described by the following equation:

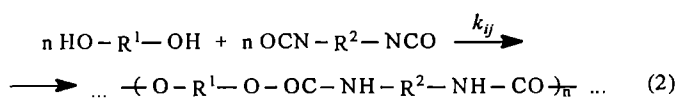

where: R_1 — aliphatic or (less frequently) aromatic unit derived from a polyol like polyether, R_2 — aromatic, aliphatic or cycloaliphatic radical of a diisocyanate monomer.

Process engineers should analyze any specific reaction system to decide if such simplifications are permissible. By way of illustration, the probability of allophanate branching, as assessed experimentally for the model reaction between Izocyn T-80 and oligo(oxypropylene)diol (Rokopol D2002) where sometimes side reactions should not be neglected [4], is presented in Fig. 1.

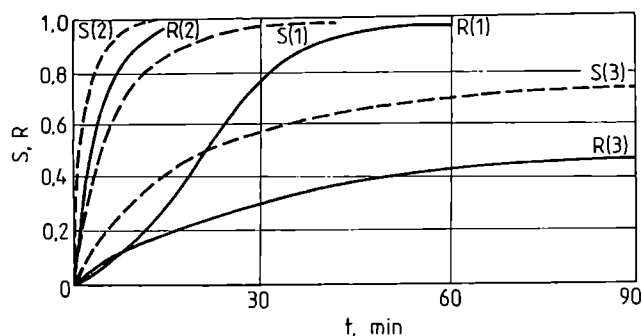

Fig. 1. Conversion degree (S — dashed line) and probability of allophanate branching (R — continuous line) versus time (t) for various PU production processes [4]

2. The kinetic scheme should enable the structures of the resulting macromolecules to be presented. Typical structures of the resulting oligomers are shown in Fig. 2 [5]. The reactivities of the functional groups taking part in the reactions specified should be known from earlier model studies and should be represented by a well-defined rate constant which depends on temperature, catalyst type, and polarity of the reaction medium. Thus, the functional groups $-NCO$ and $-OH$ that are chemically nonequivalent, e.g. in 2,4-TDI, or ones that additionally offer different reactivities due to the substitution effect in monomers or oligomers, specific mainly for aromatic diisocyanates, e.g. 2,4-TDI and 2,6-TDI, must be differentiated by way of attributing different rate constants to the individual reactions in which they participate.

For this purpose, the functional groups in monomers were designated with block letters, whereas the corresponding groups in urethane oligomers and polyurethanes were designated with small letters (Fig. 2), viz., $-OH$ groups in monomers and urethane-hydroxyl oligomers; E, e — $-NCO$ groups at position 4 in 2,4-TDI and in isocyanate prepolymers; F, f — $-NCO$ groups at position 2 in 2,4-TDI and in isocyanate prepolymers, respectively.

3. In order to monitor the size of the resulting macromolecules, it is not enough to differentiate only the types of functional groups as has been done e.g. for the formation of a urea-formaldehyde resin [6]. It is also necessary to present the algorithm generating the size of macromolecules. In fact, the stepwise polyaddition of

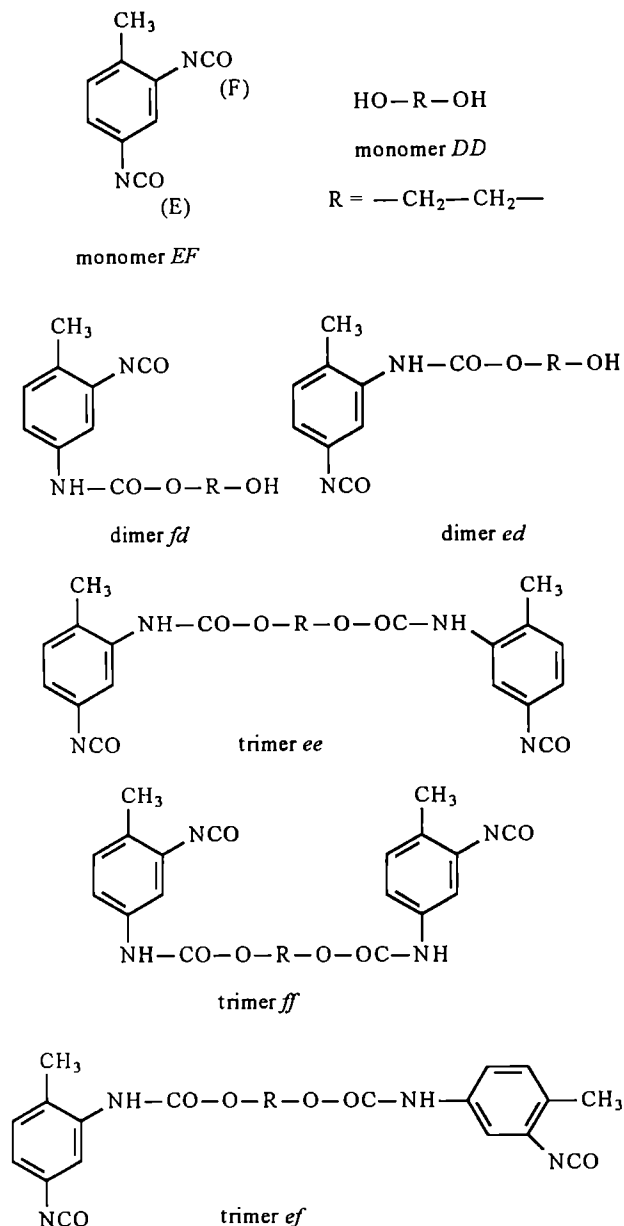
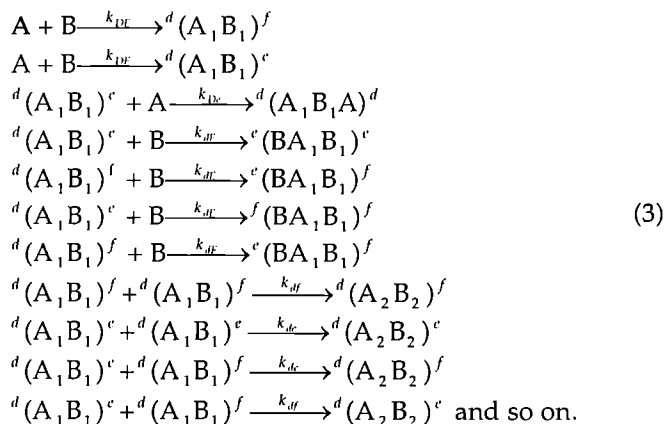

Fig. 2. Chemical structures of urethane monomers and oligomers [5]

diisocyanate to diol can be presented as a system of successive and irreversible reactions which yields bigger and bigger urethane oligomers and polymers [2]:



In this scheme, which makes use of the above-mentioned code of functional groups (Fig. 2), A denotes the bifunctional hydroxyl monomer, B — the isocyanate monomer, A_nB_n is the oligourethane with the terminal group -NCO on one side (*e* or *f*) and -OH on the other side (*d*), BA_nB_n is the diisocyanatourethane terminated with groups (*ee*, *ef* or *ff*) and A_nB_nA is the urethane-diol type oligourethane (*dd*). Each rate constant is subscripted to refer to the functional groups which are involved in this specific reaction (e.g. k_{ij} — second-order rate constant; $i = E, e, F, f$; $j = D, d$).

To put order among the reactants and to reduce their number, and thus also the number of chemical equations, the reacting substances were arranged in suitable fractions; and the concept of the polymer fraction of the *n*-th order was introduced. The fractions were divided into even-order fractions F2, F4, F6 ..., F2*n*, containing two types of oligomers, ${}^d(A_iB_i)^e$, and ${}^d(A_iB_i)^f$, and the odd-order fractions, F1, F3, F5 ..., F(2*n*-1), composed of four types of oligomers, ${}^d(A_iB_iA)^d$, ${}^e(BA_iB_i)^e$, ${}^e(BA_iB_i)^f$ and ${}^f(BA_iB_i)^f$, as differentiated in Fig. 2, where the odd fraction F1 refers only to monomers A and B, and the fraction F2 refers to dimers, etc.:

$$\begin{aligned} [F_1] &= [A] + [B] \\ [F_2] &= [{}^d(A_1B_1)^e] + [{}^d(A_1B_1)^f] \\ [F_3] &= [{}^d(A_1B_2)^e] + [{}^d(A_1B_2)^f] + [{}^e(A_1B_2)^e] + [{}^d(A_2B_1)^d] \\ [F_4] &= [{}^d(A_2B_2)^e] + [{}^d(A_2B_2)^f] \text{ and so on.} \end{aligned} \quad (4)$$

Following this convention the kinetic scheme of stepwise polyaddition, e.g. of 2,4-TDI to 1,4-butanediol, comprises 32 reaction types (Table 1) [2, 5].

CONSTRUCTION OF THE MATHEMATICAL MODEL OF STEPWISE POLYADDITION

The mathematical model based on the present kinetic scheme is in fact a system of differential equations which describe changes in the concentration of reacting substances in time in a specific polymerization reactor. Hence, it is necessary to deduce from model studies the kinetics of the reactions of functional groups so as to describe the process in terms of the kinetic equations of relevant order. Most investigators believe the rate of reaction (1) to be describable by a second-order kinetic equation [7, 8] and our study on changes in the concentrations of -NCO groups with time in the reactions of various diisocyanates with polyols (Figs. 3, 4), has also confirmed it [9].

Following Flory's postulate [10] that the reactivities of active sites, i.e. the final functional groups, in polycondensation and polyaddition are independent from the polymer chain size and depend only on the polymer chain structure, the substitution effect p_1 specific for 2,4- and 2,6-TDI can be precisely defined. Assuming the same substitution effect to occur for the two isocyanate groups, we obtain:

Table 1. General kinetic scheme for stepwise polyaddition process involving 2,4-TDI and 1,4-butanediol

Reaction type No.	Isocyanate reactant	Hydroxyl reactant	Rate constant	Product
1	EF	DD	$2k_{ED}$	fd
2	EF	DD	$2k_{FD}$	ed
3	EF	ed	k_{Ed}	ef
4	EF	ed	k_{Fd}	ee
5	EF	fd	k_{Ed}	ff
6	EF	fd	k_{Fd}	ef
7	EF	dd	$2k_{Ed}$	fd
8	EF	dd	$2k_{Fd}$	ed
9	ed	DD	$2k_{cD}$	dd
10	fd	DD	$2k_{fD}$	dd
11	ec	DD	$4k_{cD}$	ed
12	ef	DD	$2k_{cD}$	fd
13	ef	DD	$2k_{fD}$	ed
14	ff	DD	$4k_{fD}$	fd
15	ed	ed	$2k_{cd}$	ed
16	fd	fd	k_{cd}	fd
17	ed	ed	k_{fd}	ed
18	ed	ed	$2k_{cd}$	ee
19	ed	ed	k_{cd}	ef
20	ed	ed	k_{fd}	ee
21	ed	ed	$2k_{fd}$	ef
22	dd	dd	$2k_{cd}$	dd
23	fd	fd	$2k_{fd}$	fd
24	fd	fd	$2k_{cd}$	ef
25	fd	fd	k_{cd}	ff
26	fd	fd	k_{fd}	ef
27	fd	fd	$2k_{fd}$	ff
28	dd	dd	$2k_{fd}$	dd
29	dd	dd	$4k_{cd}$	ed
30	dd	dd	$2k_{cd}$	fd
31	dd	dd	$2k_{fd}$	ed
32	dd	dd	$4k_{fd}$	fd

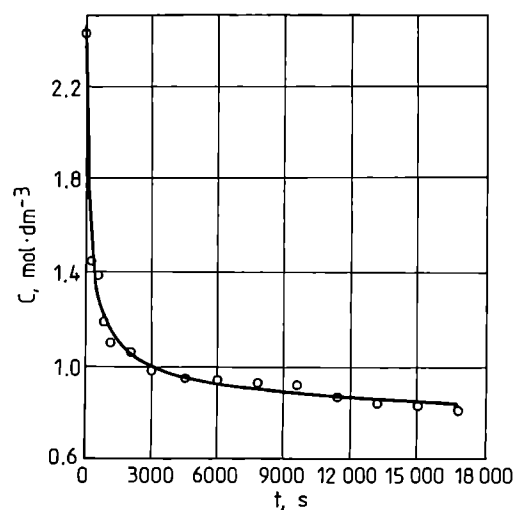

Fig. 3. Concentration of -NCO groups versus time in the reaction of 1,4-butanediol with TDI ($[NCO]_0:[OH]_0 = 1.5:1$, $T = 50^\circ C$)

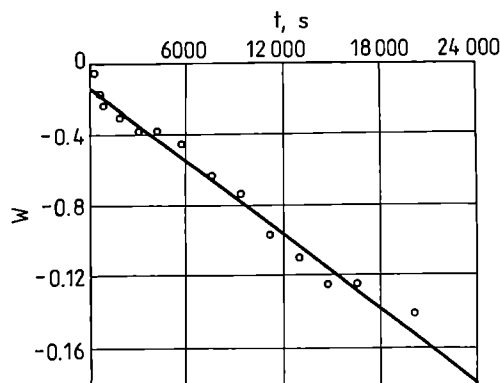

Fig. 4. Expression $W = \log_{10} \frac{([NCO]_0(1/r-1) + [NCO]_0) \cdot r}{[NCO]}$
 $= \frac{[NCO]_0(1/r-1)}{2.303} \cdot kt$ versus time in the reaction of Roko-
 pol D2002 and TDI ($[NCO]_0:[OH]_0 = 1.5:1$, $T = 50^\circ\text{C}$)

$$\frac{k_{ED}}{k_{cD}} = \frac{k_{FD}}{k_{fD}} = p_1 \quad (5)$$

In some diisocyanates, the -NCO groups can reveal different chemical reactivities relative to the compounds with labile hydrogen atoms. This is, for example, the case with the 2,4-TDI isomer. Then, another parameter (p_2) has to be introduced, viz.

$$\frac{k_{ED}}{k_{FD}} = \frac{k_{Ed}}{k_{Fd}} = \frac{k_{cD}}{k_{fD}} = \frac{k_{cd}}{k_{fd}} = p_2 \quad (6)$$

In this way, diversification of the reactivities of -NCO groups is assumed to be identical in the monomer (groups E and F) and in the urethane oligomers derived from this compound (groups e and f).

For simplification, the volume of the reaction mixture was assumed to remain unchanged in the polymerization process, which is true only in solvent polymerization which proceeds in moderate-viscosity systems

$$V(t) = \text{const} \quad (7)$$

a process specific, among other things, for the production of polyurethanes to be used for making prepolymer intermediates. Then, on the basis of the well-known general design equation for a batch reactor with ideal mixing (diffusion effects neglected), and on the basis of the kinetic model (2), a mathematical model was developed for the process considered. This is a system of ordinary first-order differential equations which describe changes in the concentrations of monomers, dimers, trimers, tetramers, etc., i.e. fraction F1, F2, ..., which are formed and which undergo polymerization reactions [2].

Apart from parameters p_1 and p_2 , there are 8 other kinetic parameters in this model (Table 1): k_{ED} , k_{FD} , k_{Ed} , k_{Fd} , k_{cD} , k_{fD} , k_{cd} , k_{fd} .

By assuming the activation energies of the 'urethani-sation' reaction of -NCO groups in 2,4-TDI to be additive, the number of the parameters in the model becomes reduced to three [2]: k_{ED} , p_1 and p_2 .

The isocyanate groups are chemically equivalent in most isocyanate monomers (2,6-TDI, MDI, NDI and HDI) ($p_2 = 1$), or the ratio of their reactivities is known as for 2,4-TDI ($p_2 \sim 1.5$) [11].

Thus, the number of essential parameters to be found for the model of some selected reaction systems, e.g., 2,4-TDI and BD, becomes reduced to only two most important parameters, viz., k_{ED} and p_1 .

These parameters should be estimated for each reaction system by comparing the experimental data (e.g. instantaneous concentrations of fractions F1, F2 ...) with the corresponding estimated values.

This procedure was performed for the reaction of 2,4-TDI with 1,4-butanediol carried out in a chlorobenzene-THF solution at 101°C (2:1) and 86°C (1:1) at initial equimolar concentrations of monomers A and B, $[F1]_0 = 0.768$ and 0.766 mol/dm^3 , respectively. The concentrations of fractions $[F1] + [F2]$ and $[F3] + [F4]$ calculated from the model were consistent with the corresponding \bar{M}_n -values evaluated by GPC carried out during the polyaddition. This procedure allowed to verify the model experimentally and to establish the optimum values of model parameters (8) [12]:

$$k_{ED} = 6.51 \cdot 10^{-4} \text{ dm}^3 \cdot \text{mol}^{-1} \cdot \text{s}^{-1} \text{ and } p_1 = 1.55 (86^\circ\text{C}) \quad (8)$$

$$k_{FD} = 17.2 \cdot 10^{-4} \text{ dm}^3 \cdot \text{mol}^{-1} \cdot \text{s}^{-1} \text{ and } p_1 = 1.62 (101^\circ\text{C})$$

The method used to run the process made it possible to adopt the initial conditions for the specified differential equations: $[A] = A_0$ at $t = 0$, $[B] = B_0$ at $t = 0$.

At $t = 0$, the concentration of any other component is 0.

The form of the model equations is pretty complex, yet the equations can be solved by applying modern numerical methods [2, 12]. This way enables us to establish a number of interesting relations between process conditions and properties of the resulting oligourethanes and linear polyurethanes and in particular the number-average molecular weight of linear PU:

$$\bar{M}_n(t) = \frac{\sum_{i=1}^n M_i c_i(t)}{\sum_{i=1}^n c_i(t)} \quad (9)$$

where: $c(t)$ — mole fraction of PU fraction, the conversion degree of -OH groups in the process run at an excess of diisocyanate ($r > 1.0$).

$$\alpha(t) = \frac{[OH]_0 - [OH]_t}{[OH]_0} \quad (10)$$

where: r is the index for the initial functional groups, defined as

$$r = \frac{[NCO]_0}{[OH]_0} = \frac{B_0}{A_0} \quad (11)$$

and $\alpha(t)$ is the temporary conversion degree of monomer.

Figure 5 presents the profile of function (10) obtained directly from analysis for -NCO groups [9]. As demon-

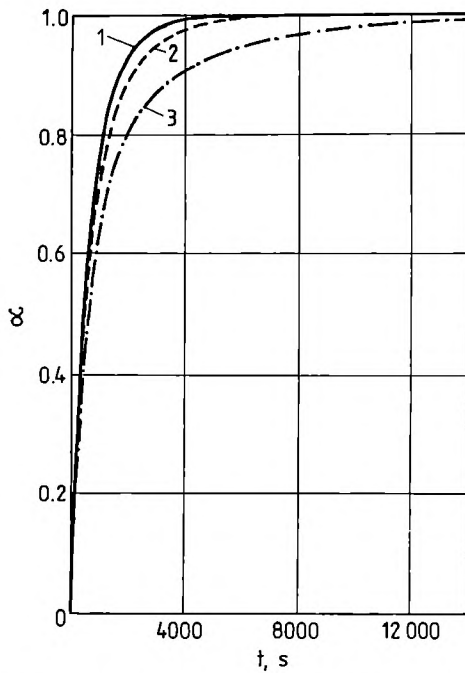

Fig. 5. Conversion degree (15) of -OH groups in the reaction producing isocyanate prepolymer ($k_{ED} = 8.00 \cdot 10^{-4} \text{ dm}^3 \cdot \text{mol}^{-1} \cdot \text{s}^{-1}$) [8]; 1 — $r = 2.0$, $[\text{NCO}]_0 = 2.59$; 2 — $r = 1.5$, $[\text{NCO}]_0 = 2.42$; 3 — $r = 1.1$, $[\text{NCO}]_0 = 2.20$

strated below, numerical calculations will make it possible to present this relationship for a wider range of variables and not for equimolar polyaddition only.

NUMERICAL SIMULATION OF POLYADDITION

The model verified as described above was used to study polyaddition of diisocyanate to polyols. Numerical simulation was carried out for the polymerization of e.g. 2,4-TDI and diol endowed with equivalent primary -OH groups like in 1,4-butanediol, to be run for 5 hours, a period of time close to the actual time used in solvent polymerization. The standard Euler method was used to integrate numerically the differential equations. A step of 5 s was taken each time for numerical

Table 2. Variability ranges for model parameters employed in simulation calculations

Reaction temp., °C	Catalyst	$k_{ED} \cdot 10^{-4} \text{ dm}^3 \cdot \text{mol}^{-1} \cdot \text{s}^{-1}$	p_1	r
40—90	—	1—20	1—3	1—5
40—90	DABCO	8—50	1—3	1—5

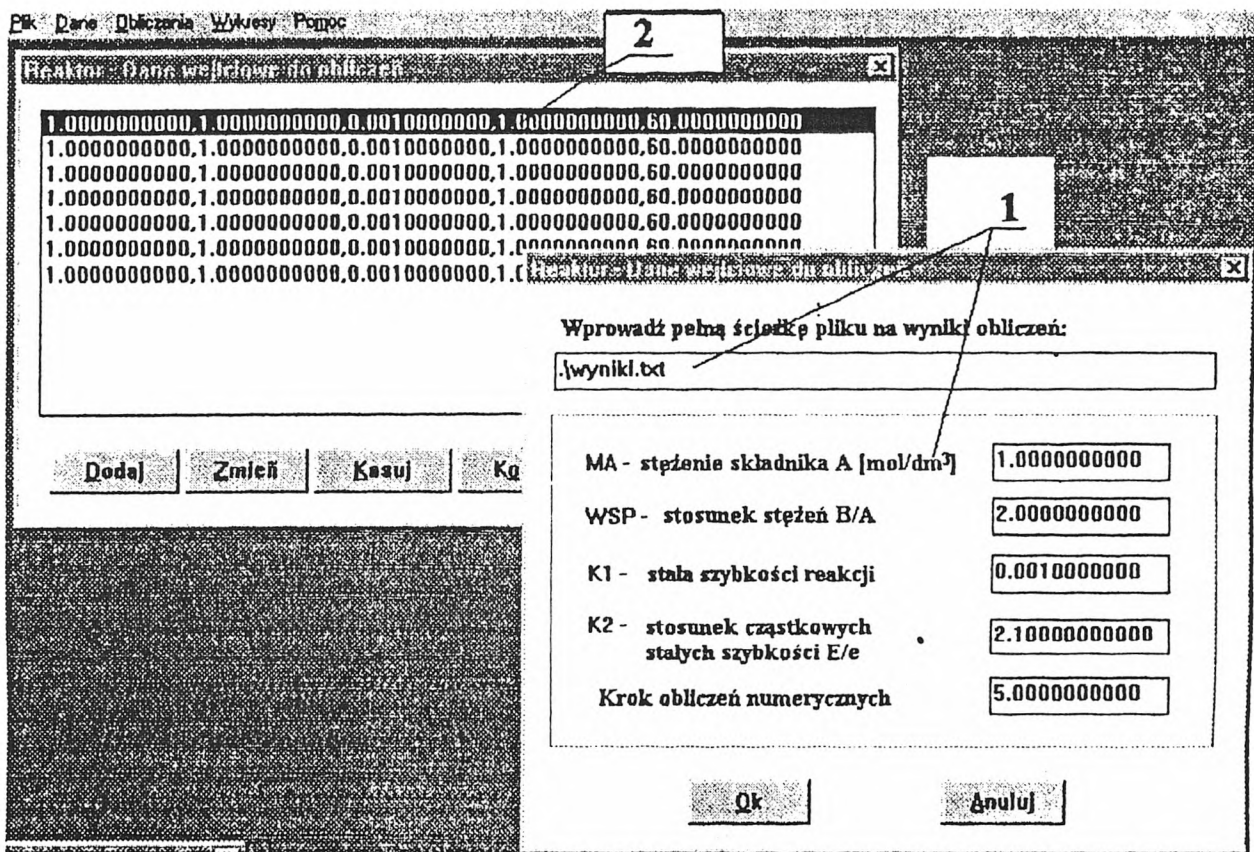

Fig. 6. The main menu for the numerical calculation software allowing to declare initial data. 1 — entering reaction conditions data; 2 — parameter combinations; instructions add, modify, delete and copy allow to modify parameters before calculation is started

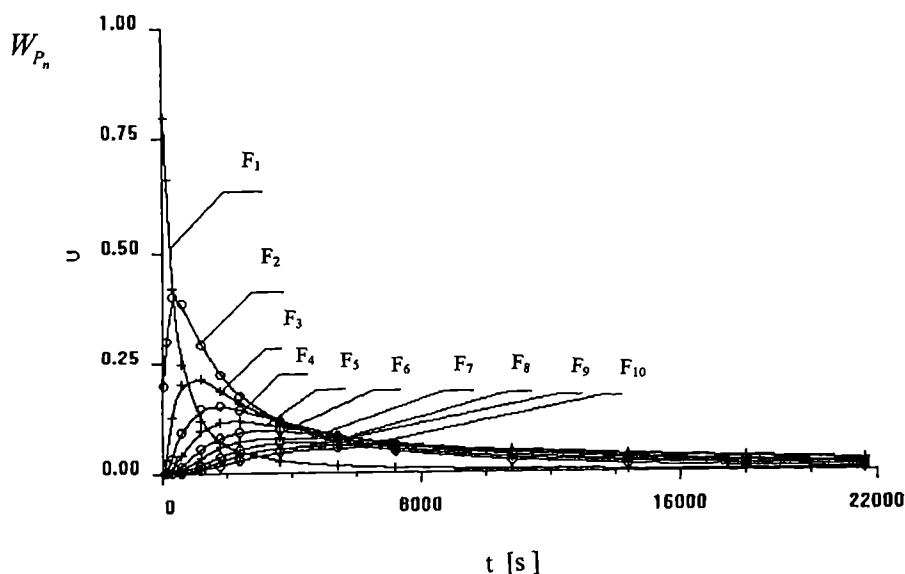

Fig. 7. Simulation of weight fraction of monomer (u_1), dimer (u_2), trimer (u_3), etc. in polyaddition of diisocyanate to polyol when: $[A]_0 = 1.0 \text{ mol/dm}^3$, $r = 1.00$, $k_{ED} = 10^{-3} \text{ dm}^3 \cdot \text{mol}^{-1} \cdot \text{s}^{-1}$, $p_1 = 2.0$, $h = 5 \text{ s}$

integration and the initial concentration of monomer A selected for the calculations was $A_0 = 1 \text{ mol/dm}^3$.

The variability ranges of model parameters result from both the need for identifying the effects due to structural specificity of the reacting compounds (p_1) and to a number of process parameters (time, temperature, catalyst type) which affect the value of k_{ED} (Table 2) and the properties of resulting PU. Previous investigations have shown this constant to vary within $(5\text{--}25) \cdot 10^{-4} \text{ dm}^3 \cdot \text{mol}^{-1} \cdot \text{s}^{-1}$ as a result of an increase in the temperature from 40°C to 90°C . However, the possible presence of a popular catalyst like 1,4-diazabicyclo-2,2,2-octane (DABCO) can produce much higher changes in the constant k_{ED} , i.e. $(20\text{--}50) \cdot 10^{-4} \text{ dm}^3 \cdot \text{mol}^{-1} \cdot \text{s}^{-1}$ [4, 8].

The basic requirement to be met by the simulation software developed was to readily introduce the kinetic parameters of polyaddition. Again, numerical and/or graphical form of the results, convenient for interpretation, was required to be available. The system of windows-menus was utilized, which makes introduction of the following initial conditions/data (Fig. 6) easy:

- concentration of monomer, A, mol/dm^3 ;
- initial molar ratio of monomers B and A, (r) dimensionless quantity;
- reaction rate constant, (k_{ED}), $\text{dm}^3 \text{ mol}^{-1} \text{ s}^{-1}$;
- ratio of reactivities for both isocyanate groups, p_1 , dimensionless quantity;
- step in numerical calculations of the polyaddition process, s.

The system adopted makes it possible to name a file where all the results of the numerical calculations will be stored.

The software requires Windows 95 and all you need to open this application is to click a suitable icon. After having specified the data listed above, the calculation

can be started and the results are available as an ASCII file with can be immediately copied and/or retrieved into the known graphical software (Excel, Origin) and further processed to obtain the required graphical form of two-dimensional and three-dimensional charts. Results of simulation are also available at any moment in the form of two-dimensional charts which present changes in the following quantities (as a function of the reaction time):

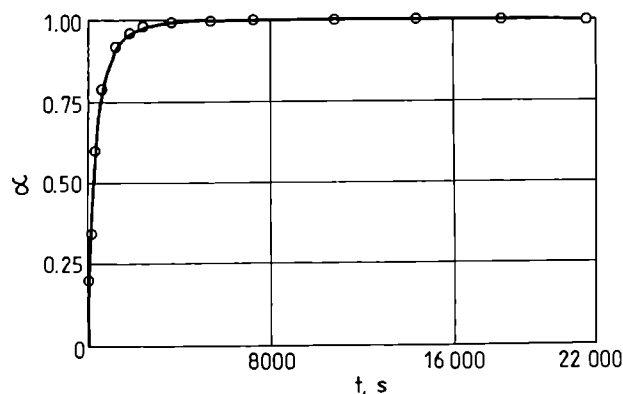

Fig. 8. Degree of conversion, α , of $-\text{OH}$ groups in polyaddition of diisocyanate to polyol, for the conditions as in Fig. 7

- concentrations of monomer, dimer, trimer, etc., usually up to fraction F10, expressed as mole or mass fractions (Fig. 7);
- degree of conversion (10) (Fig. 8);
- average molecular weight of the resulting polyadduct (9) (Fig. 9).

Results of calculation can be presented in various configurations. They allow to infer about the effects of the polymerization regime (time, temperature, ratio of

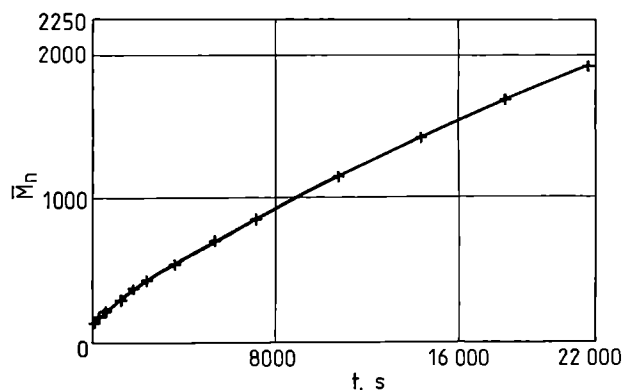

Fig. 9. Average molecular weight (\bar{M}_n) in polyaddition of diisocyanate to polyol, for the conditions as in Fig. 7

monomers) and the polyurethane structure (polymerization degree, distribution of molecular weights, concentration of unreacted monomers). In analyzing the data, the limitations built into the model must always be kept in mind; in this case, side reactions have been ignored, which are possible for isocyanate groups.

RESULTS AND DISCUSSION

It is the final concentration of the functional groups that is important in polycondensation. In preparing polyurethane elastomers and foams attempts are made to achieve, under given conditions, a maximum possible conversion of hydroxyl and isocyanate groups. This approach favors the production of a polymer with a possibly high degree of polycondensation and reduces to minimum the final concentration of unreacted isocyanate monomers which are toxic and reactive with moisture (humid environment). Again, too high a viscosity of a prepolymer having relatively high macromolecules may be unfavorable to further processing of these materials. The molar ratio of functional groups r (11) has a critical influence on the size of macromolecules (Fig. 10), as is shown by the Carothers equation:

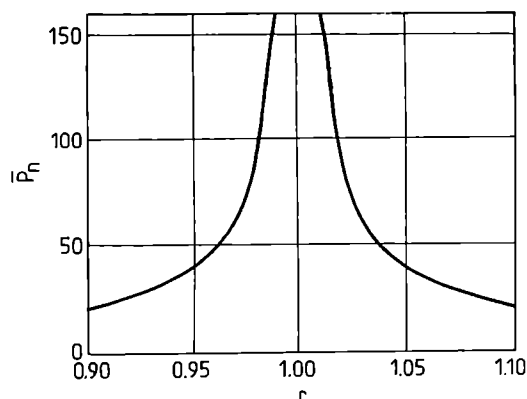

Fig. 10. Polycondensation degree \bar{P}_n versus mole ratio of reactants (r) in stepwise polymerization [10]

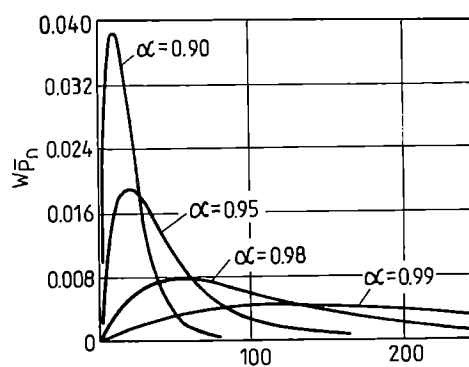

Fig. 11. Theoretical molecular weight distributions of linear polymer in the polycondensation at various conversion degrees α [10]

$$\bar{P}_n = \frac{1+r}{1+r-2\alpha} \quad (12)$$

where: \bar{P}_n average polycondensation degree.

By Flory's equation [12], the conversion degree α (10) is decisive for the poly-molecularity of the polymer produced. The distribution of the molecular weight in the linear polyurethane obtained from bifunctional monomers is described by the following equation (for $r = 1$) (Fig. 11):

$$w_x = P_n \cdot \alpha^{p_n-1} \cdot (1-\alpha)^2 \quad (13)$$

The model developed makes it possible to calculate both the conversion degree of functional groups and the average molecular weight. As expected, the most significant impact on the conversion degree of functional groups in a non-catalyzed reaction is due to temperature, which affects the rate constant k_{ED} , as evident from Fig. 12 for a non-catalyzed process and Fig. 13 for a process catalyzed with 1,4-diazabicyclo-2,2,2-octane

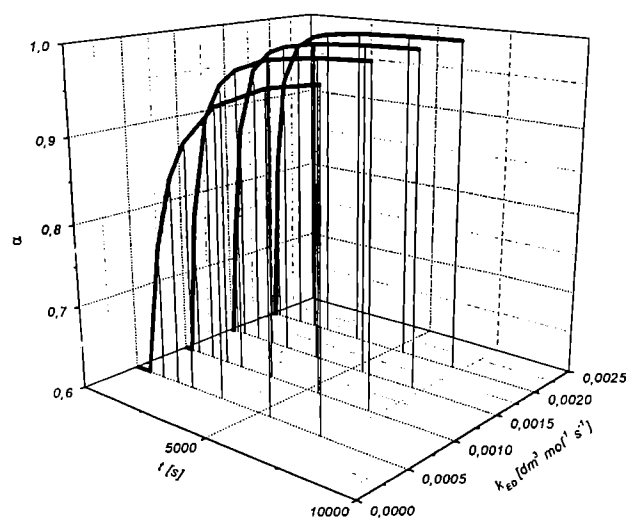

Fig. 12. Conversion degree α of $-OH$ groups in relation to rate constant k_{ED} (temperature) and time, for non-catalyzed stepwise polyaddition ($r = 1$, $p_1 = 1.0$)

(DABCO). The efficient catalyst is seen (Fig. 13) to have accelerated the process so much that the maximum conversion degree α is obtained in the first hour of the process. This way allows to analyze the efficiency offered by various catalytic systems. The model allows also to predict the average molecular weight of the resulting PU. Under the conditions specified, the values of \bar{M}_n of the oligomers produced fall within 1,000–3,000 g/mol (non-catalyzed reaction) (Fig. 14) and are more than twice as high in the catalyzed reaction (Fig. 15). Analogous dependencies for non-equimolar reactions which yield isocyanate prepolymers ($r > 1$) are presented graphically in Figs. 16 and 17. Under these conditions, -OH groups can be expected to react faster and nearly to completion. The oligomers formed have a much lower

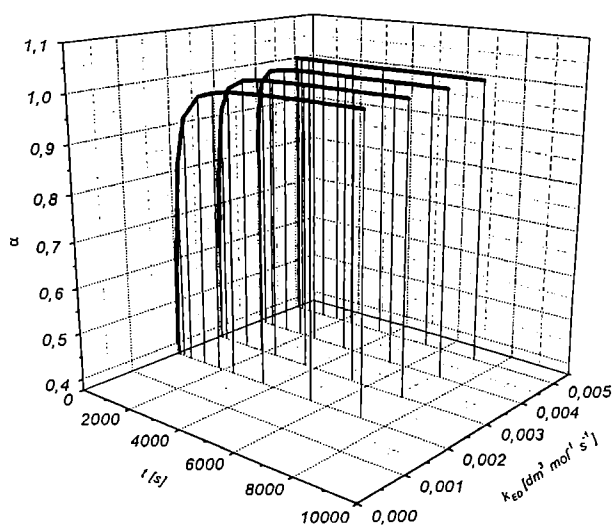

Fig. 13. Conversion degree α of -OH groups in relation to rate constant k_{ED} (temperature) and time, for DABCO-catalyzed process of stepwise polyaddition ($r = 1$, $p_1 = 1.0$)

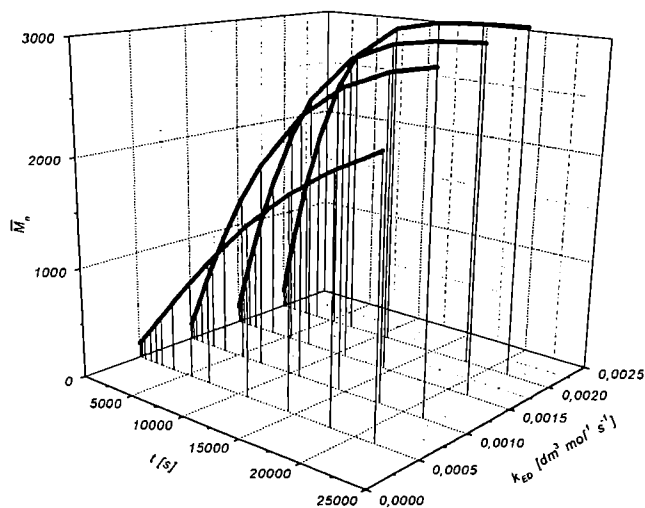

Fig. 14. Average molecular weight \bar{M}_n of urethane oligomers in relation to rate constant k_{ED} (temperature) and time, for non-catalyzed stepwise polyaddition ($r = 1$, $p_1 = 1.0$)

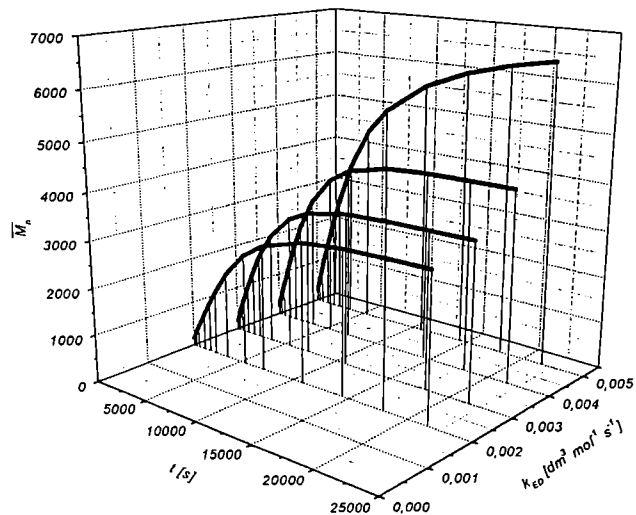

Fig. 15. Average molecular weight \bar{M}_n of urethane oligomers in relation to rate constant k_{ED} (temperature) and time, for DABCO-catalyzed stepwise polyaddition ($r = 1$, $p_1 = 1.0$)

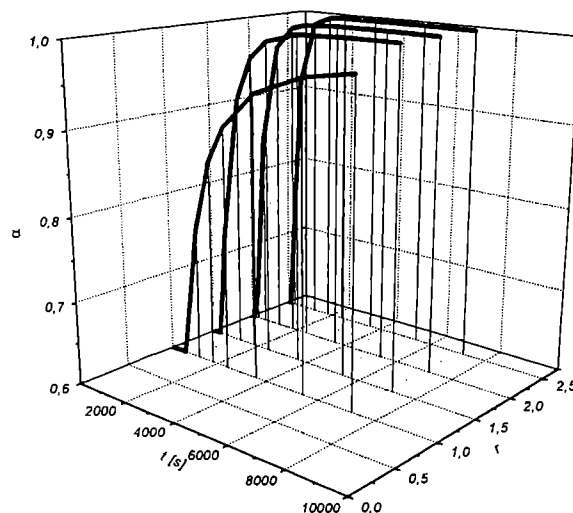

Fig. 16. Conversion degree α of -OH groups in relation to index r and time in non-stoichiometric polyaddition ($k_{ED} = 5 \cdot 10^{-4} \text{ dm}^3 \cdot \text{mol}^{-1} \cdot \text{s}^{-1}$, $p_1 = 1.0$)

average molecular weight (Fig. 17), just as foreseen (Fig. 10).

Numerical solution of the model equations gives directly the relationships which describe changes in the concentrations of successive polyurethane fractions. Some examples of such relations are presented in Figs. 18–20 (non-catalyzed process) and in Fig. 21 (catalyzed process). In the latter case, the relationships can be obtained for higher fractions.

A particularly interesting information on progress of the process can be deduced from analysis of the substitution effect p_1 (5) which is specific to aromatic diisocyanates containing in addition to -NCO groups, other substituent groups at the ring. The calculations suggest that the lower activity of -NCO groups in oligomers in

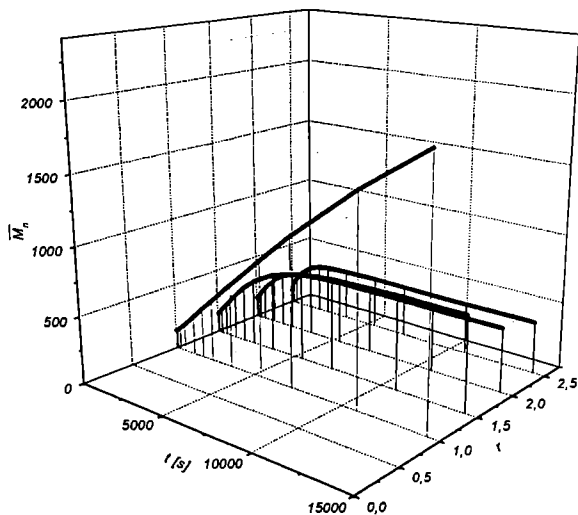

Fig. 17. Average molecular weight \bar{M}_n of urethane oligomers in relation to index r and time in non-stoichiometric polyaddition ($k_{ED} = 5 \cdot 10^{-4} \text{ dm}^3 \cdot \text{mol}^{-1} \cdot \text{s}^{-1}$, $p_1 = 1.0$)

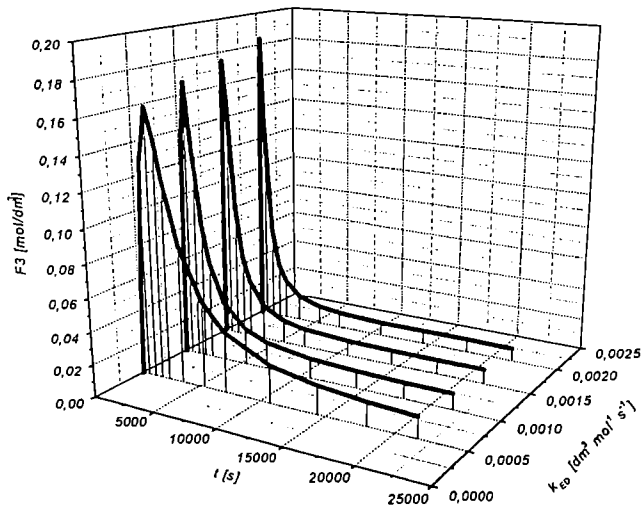

Fig. 20. Trimer concentrations (fraction F3) versus rate constant k_{ED} (temperature) and time non-catalyzed stepwise polyaddition ($r = 1$, $p_1 = 1.0$)

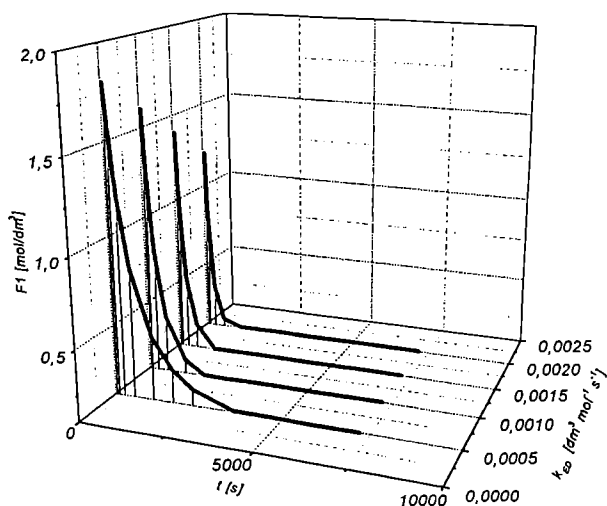

Fig. 18. Monomer concentrations (fraction F1) versus rate constant k_{ED} (temperature) and time non-catalyzed stepwise polyaddition ($r = 1$, $p_1 = 1.0$)

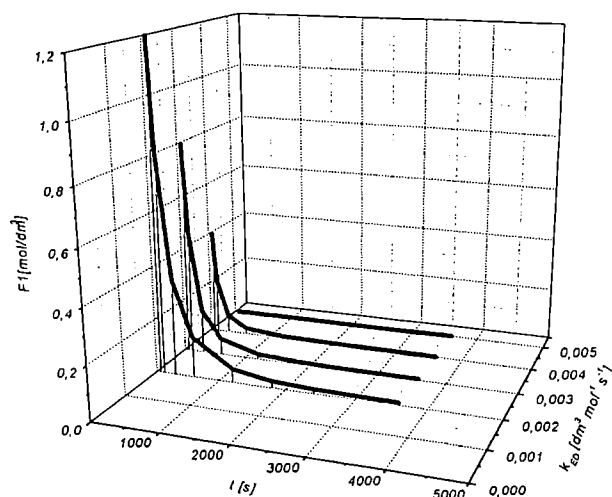

Fig. 21. Monomer concentrations (fraction F1) versus rate constant k_{ED} (temperature) and time DABCO-catalyzed stepwise polyaddition ($r = 1$, $p_1 = 1.0$)

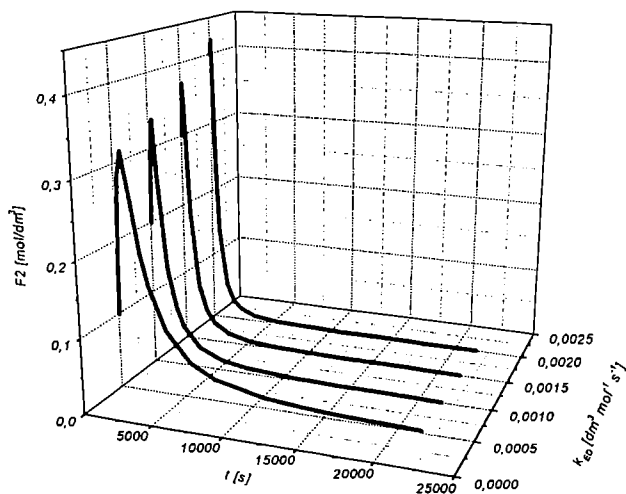

Fig. 19. Dimer concentrations (fraction F2) versus rate constant k_{ED} (temperature) and time non-catalyzed stepwise polyaddition ($r = 1$, $p_1 = 1.0$)

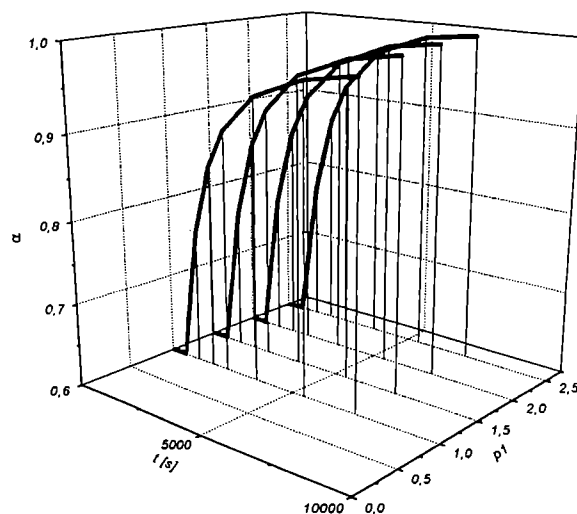

Fig. 22. Conversion degree α of -OH groups versus substitution effect p_1 and time in stepwise polyaddition process ($k_{ED} = 5 \cdot 10^{-4} \text{ dm}^3 \cdot \text{mol}^{-1} \cdot \text{s}^{-1}$, $p_1 = 1.0$)

relation to their corresponding end groups in the reacting polyurethanes (a higher p_1 parameter) results in a lower rate of the principal reaction which is responsible for the growth of macromolecules (Fig. 22). This, however, is of no practical importance for the process based on a specific monomer since the substitution effect remains unchanged for a given diisocyanate compound. Yet, when prepolymer mixtures are produced from different diisocyanates, the reactivities of the mixture components can be different, and this should be considered in designing technological lines.

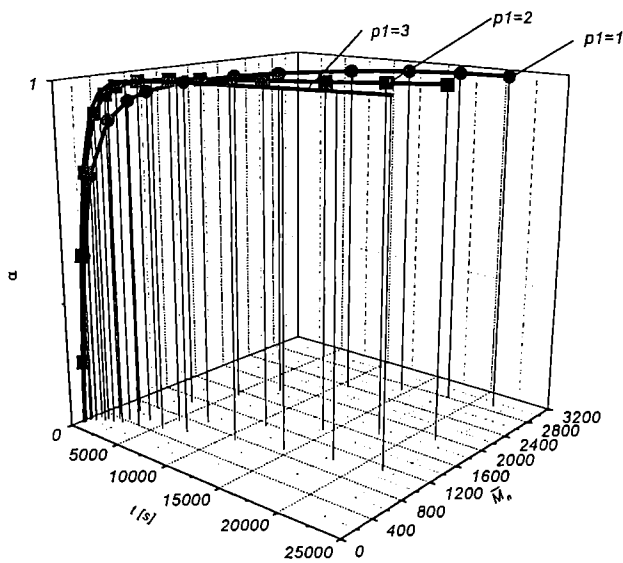

Fig. 23. A three-dimensional plot showing the mutual effects of process parameters (α , t , \bar{M}_n , p_1) in stepwise polyaddition of diisocyanate to diol ($k_{ED} = 10^{-3} \text{ dm}^3 \cdot \text{mol}^{-1} \cdot \text{s}^{-1}$, $p_1 = 1.0$)

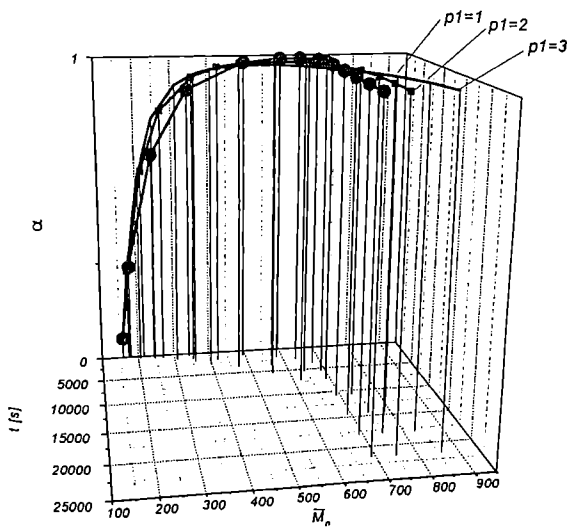

Fig. 24. A three-dimensional plot showing the mutual effects of process parameters (α , t , \bar{M}_n , p_1) in non-stoichiometric polyaddition of diisocyanate to diol ($k_{ED} = 10^{-3} \text{ dm}^3 \cdot \text{mol}^{-1} \cdot \text{s}^{-1}$, $p_1 = 1.0$)

In spite of what might be expected, the substitution effect p_1 was found to have a complex influence on the process analyzed, hardly evident from experimental measurements. This effect is demonstrated in three-dimensional model projections which simulate the equimolar (Fig. 23) and the non-equimolar process (Fig. 24). A complex view on the final conversion degree α in relation to molar ratio r , molar weights of the reacting substances \bar{M}_n in polyaddition (characterized by rate constant k_{ED}) involving polyols and diisocyanates with various reactivities p_1 is presented in Fig. 25. By assu-

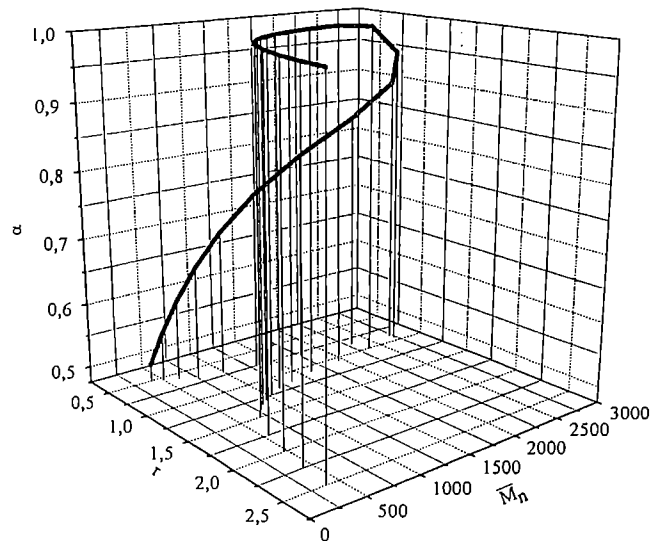

Fig. 25. The final conversion degree (α) of reactants and \bar{M}_n -values in time $t = 10,800 \text{ s}$ for the reaction of diisocyanate with $p_1 = 1.0$ with diol at various initial ratios of monomers (r) and at a constant value of $k_{ED} = 10^{-3} \text{ dm}^3 \cdot \text{mol}^{-1} \cdot \text{s}^{-1}$

ming some specific reaction parameters, one can analyze at any moment a number of properties of the resulting PU (values of \bar{M}_n , concentrations of polymer fractions). This certainly helps in arriving at pre-defined properties of the PU moulding processes involving the RIM and other methods.

CONCLUSION

As may be seen from the analysis performed, the general model developed makes it possible to arrange some complex optimization experiments which are essential for polyurethane production processes. The use of experimentally verified model parameters in the numerical calculations makes this method especially applicable and useful for process design purposes. The possibility and ease of performing model studies makes the kinetic constants available for other reactions. Hence, the calculation software developed becomes applicable in the analysis of new reaction systems of diisocyanates, polyols and catalysts for the polyaddition process.

NOMENCLATURE

PU — polyurethane
 A, B — hydroxyl and isocyanate monomers
 [OH], [NCO] — temporary concentrations of functional groups
 [OH]₀, [NCO]₀ — initial concentrations of functional groups
 A₀, B₀ — initial concentrations of monomers
 F1, F2 ... F5 — fractions of PU
 D, d — -OH groups in monomers and urethane-hydroxyl oligomers
 E, e — -NCO groups at position 4 in 2,4-TDI and in isocyanate prepolymers
 F, f — -NCO groups at position 2 in 2,4-TDI and in isocyanate prepolymers
 p₁ — kinetic constant for substitution effect in 2,4-TDI (eqn. 5)
 p₂ — kinetic parameter (eqn. 6)
 k_{ij} — second-order rate constant (i = E, e, F, f; j = D, d)
 t — reaction time (s or min)
 T — temperature, °C
 m, n — natural numbers
 \bar{M}_n — number-average molecular weight of polymer, g/mol (11)
 c(t) — mole fraction of PU fraction (eqn. 9)
 α(t) — temporary conversion degree of monomer (eqn. 12)
 r — index for functional groups (eqn. 11)
 \bar{P}_n — average polycondensation degree (eqn. 12).
 W_x — molecular weight distribution in polymer (eqn. 13)
 h — step in numerical integration

ACKNOWLEDGMENTS

This work was carried out within the Research Project No. 3T09B 151 10 which was financially supported by the State Committee for Scientific Research.

The Authors wish also to thank Ryszard Słoma M. Sc. for collaboration in developing the "Reaktor" program and Witold Pękala M. Sc. who translated this study into English.

REFERENCES

1. Król P.: *Przem. Chem.* 1998, **77**, 411.
2. Król P., Gawdzik A.: *Pol. J. Appl. Chem.* 1998, in press.
3. Galina H.: *Polimery* 1997, **42**, 421.
4. Król P., Atamańczuk B., Pielichowski J.: *J. Appl. Polym. Sci.* 1992, **46**, 2139.
5. Król P.: *J. Appl. Polym. Sci.* 1998, **69**, 169.
6. Kumar A., Sood A.: *J. Appl. Polym. Sci.* 1990, **40**, 1473.
7. Dubois C., Desiles S., Ait-Kadi A., Tanguy P.: *J. Appl. Polym. Sci.* 1995, **58**, 873.
8. Schwetlick K., Noack R.: *J. Chem. Soc. Perkin Trans.* 1995, **2**, 395.
9. Król P.: unpublished papers (1997).
10. Flory P. J.: "Principles of Polymer Chemistry", Cornell University Press, Ithaca, New York 1953.
11. Papava G. Sh., Maisuradze N. A., Zharkua Z. L.: *Polym. Acta* 1988, **39**, 445.
12. Król P., Galina H., Kaczmarski K.: *Makromol. Chem. Theory Simul.*, in press.

Received 17 XII 1998.