

EWA KICKO-WALCZAK

Industrial Chemistry Research Institute
Department for Medical Polymers and Materials
8, Rydygiera Street, 01-793 Warsaw

Cone calorimetric studies on the mechanism of action of new fire-retardants used for polyester resins

Summary — Cone calorimetry was used to carry out a complex analysis of the pyrolysis of selected glass-reinforced polyester laminates (GRPL) based on two compositions of unsaturated polyester resins (UPR) fire-nonretarded and fire-retarded and smoke suppressed by the use of mixtures of zinc hexahydroxystannate $ZnSn(OH)_6$ and zinc borate or zinc molybdate. The heat release (average) rate (HRR and HRR_{av}), time required to ignite a GRPL, the mass loss rate and (average) surface extinction area (SAE and SAE_{av}) were studied in relation to thermal irradiation power and to presence or absence of a fire retardant. The cone calorimeter is shown to enable all the stages of pyrolysis of GRPL involving combustion and smoke emission, to be analyzed. It was confirmed effective influence of the Sn/Zn systems as a fire retardants additive for polyester resins.

Key words: cone calorimetry, glass-reinforced polyester laminates, flammability, smoke emission, evaluation of fire retardants

Fire retardancy of polymeric materials has long been studied at several national centers and by numerous European and American companies. These studies have been focused primarily on the mechanism of the polymer combustion phenomena, on new fire retardants, toxicity, improvement of flammability tests and evaluation of the degree of fire-retardancy and standardization of products.

An essential problem encountered in conflagrations involving plastics is the emission of smoke. This hazard is particularly imminent when curable polymers of the unsaturated polyester resin (UPR) type are used and less so when thermoplastics are involved. I have already presented [1] a general characteristics of the course of combustion of UPR and of glass-reinforced polyester laminates (GRPL) and also described the principles underlying the fire retardancy of such products. Related information has also been presented elsewhere [2—6].

Generally, flame retardancy is achieved by modification of polyester resins involving introduction of additive fire-retardants [3, 4]. The most effective modifiers should change the course of the chemical reactions occurring on pyrolysis of UPR or GRPL so as to reduce the content of aromatic hydrocarbons in the products which, on burning, produce soot and to increase the content of aliphatic hydrocarbons. This way increases the amount of coal passing to the solid residue, known as the "coke".

Emission of smoke and toxic gases is related to the chemical composition of a burning UPR. It should be

emphasized, however, that even a specially designed structure of the polyester backbone does not guarantee that the resulting product will be difficult to burn to. Therefore, it was deemed to be advisable to use modifiers whose relatively low percentages reduce combustion and emission of smoke [6].

To characterize the flammability and to class the polymeric materials into suitable categories of fire resistance requires the combustion factors to be fully established, including the ignition temperature, the time to start burning, the rate of burning, the time of spontaneous burning, the scope of burning and the percentage of char. TGA, DTA, gas chromatography and mass spectrometry are helpful in following the combustion phenomena. The most objective and representative of the behavior of polymers on burning are now considered to be studies carried out by the use of cone calorimetry [8—11], which involve the measurement of the rate of heat evolution and generation of smoke released from various materials.

EXPERIMENTAL

Materials

Polimal 120 (ZCh Organika-Sarzyna, Sarzyna, Poland), isophthalic-maleinic-propylene polyester resin; styrene, 35%; no halogens.

Polimal 161 (ZCh Organika-Sarzyna, Sarzyna, Po-

land), a maleic-phthalic-epichlorohydrin polyester resin with an incorporated bromine compound; styrene, 35%; 9.3% Cl + 6.7% Br.

Polimal HET/Cl (ZCh Organika-Sarzyna, Sarzyna, Poland), a polyester resin prepared from maleic anhydride, hexachloroendomethylenetetrahydrophthalic (HET) acid and diethylene glycol; styrene, 33%; Cl, 21%.

A borosilicate glass roving, surface weight 450 g/m².

Zinc hexahydroxystannate (ALCAN Chemical Europe, UK).

Zinc borate, 2 ZnO · 3 B₂O₃ · 3 H₂O (ALCAN Chemical Europe, UK).

Zinc molybdate, ZnMoO₄ (Sherwin-Williams Chemical, UK).

Antimony trioxide (POCh, Gliwice, Poland).

Ketonox, methyl ethyl ketone peroxide, a 40% solution in dimethyl phthalate.

Cobalt naphthenate, a 1% Co solution in styrene.

Preparation of samples

Three GRPL samples 100 × 100 × 100 mm in size were examined, each representing a polyester composition selected as a result of preliminary fire-retardancy study and each containing or not containing selected fire-retardants. The samples were conditioned at 23 ± 2°C, at R. H. 50 ± 5%, to constant weight (±1%). Before being examined, the sample was wrapped into an aluminum film and screened at the back with a ceramic blanket and then fixed in a holder inside the calorimetric chamber. The samples were exposed in a horizontal position to thermal radiation of a selected power equal to 25, 35 or 50 kW/m². A sparking igniter was used to ignite gases.

Methods of study

Earlier studies on flame retardancy of selected polyester materials carried out by different techniques and reported elsewhere [1, Table 1] served us to select the most efficient fire retardants constituting primarily the Sn/Zn system for the present cone calorimetry studies ("Cone 2" type calorimeter, ATLAS Electronic Devices Co.). Two GRPL laminate types were chosen, based on the following polyester compositions:

(A) chlorinated Polimal HET/Cl and nonhalogenated Polimal 120 containing ZnSn(OH)₆ + 2 ZnO · 3 B₂O₃ · 3 H₂O as fire-retardant, smoking intensity 12 980 lx·s, and oxygen index 39.7%;

(B) halogenated (Cl + Br) Polimal 161 and nonhalogenated Polimal 120 containing ZnSn(OH)₆ + ZnMoO₄; smoking intensity 13 459 lx·s, oxygen index 43.4%. The laminates were prepared as described elsewhere [1].

The principle of operation of the cone calorimeter is based on the laws of consumption of oxygen, *i.e.*, the heat evolved on combustion can be determined quantitatively in terms of the oxygen consumed. With most flammable materials including high-*M* plastics, organic liquids, and wood, the heat released is 13.1 MJ per 1 ki-

logram of oxygen consumed. Deviations from this average value encountered with various materials do not exceed ±5%. This value should not be confused with the heat combustion which is defined as the quantity of heat released per 1 kilogram of the material burnt.

A cone calorimeter measures the concentration of oxygen in the gases evolved and the flow rate of these gases in the exhaust. The combination of the quantity of oxygen consumed and the constant 13.1 MJ allows to establish the amount of the heat released and the rate of heat release [8, 9].

A considerable progress in the method is that results can be presented in the form of physical data characterizing the flammability properties of materials [10].

Smoke evolution was studied with the aid of a laser photometer. Results are given in rational units of "specific extinction area" which is the area (m²) of extinction produced by a unit mass (kg) of the sample. Although the scientific principles of such measurements have long been known, the cone calorimeter is the first device in which the above unit is consistent with the theory. This is the counterpart of smoke evolution.

The decrease in sample weight is expressed in kg · m⁻² and the average weight loss rate per sample's unit surface area (g · m⁻² · s⁻¹) is calculated over the experimental time from the moment of ignition until the end of the test. The sample is held on a balance which allows to measure the rate of weight loss during the test.

RESULTS AND DISCUSSION

The most essential quantity measured by the cone calorimeter is the heat release rate [q(t)] which is evaluated as

$$q(t) = (\Delta h_c / r_o)(1.10)C(\Delta p / T_o)^{0.5}(x_{O_2}^a - x_{O_2}^i) / (1.105 - 1.5x_{O_2}^i) \quad (1)$$

where: $\Delta h_c / r_o$ — constant equal to 13.1 · 10³ kJ; *C* — oxygen consumption calibration constant, (m · kg · K)^{1/2}; Δp — pressure difference, Pa; *T_o* — absolute temperature of gas, K, measured at the orifice; *x_{O₂}* — oxygen analyzer reading.

The calorimetric measurements yields a HRR curve which represents the course of heat release rate as a function of burning time. The heat released is presented as the power per exposed unit surface area, kW/m².

The HRR curves are presented (Fig. 1) for the GRPL samples containing and not containing the Sn/Zn fire-retarding system in relation to thermal radiation power. Regardless of the polyester type and irradiation power, the curves ascertained allow to distinguish the following stages. The initial segments correspond to the period of heating of the polyester, volatilization of volatile parts and evolution of gases. The length of the section is related to the power of thermal irradiation: the higher the power, the shorter the section (*cf.* Figs. 1a, c). The evolving gases become ignited. Immediately past the ignition point, the HRR curve sharply increases to produce a peak corresponding to the combustion of py-

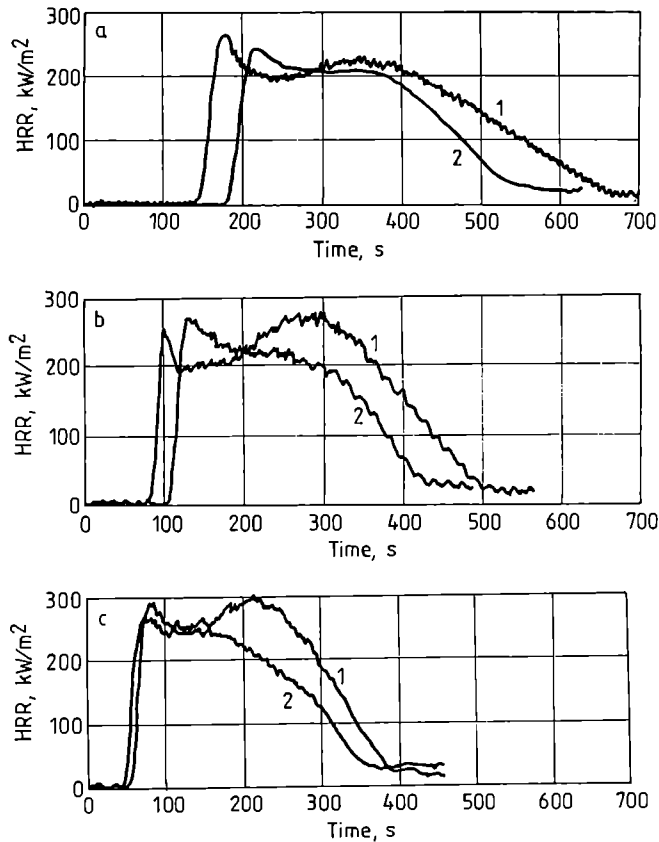

Fig. 1. The heat release rate (HRR) in relation to thermal irradiation power (kW/m^2): a — 25, b — 35, c — 50; 1 — fire-nonretarded, 2 — fire-retarded GRPL

rolyzates and evolution of a high amount of heat (ca. $250 \text{ kW}/\text{m}^2$). The time of decomposition and combustion is related to the power of thermal radiation: the higher the power, the shorter the time. In the case of fire-nonretarded GRPL, the heat release rate (HRR) increased as the power of thermal radiation was increased. The curves (Fig. 1) show that, at $25 \text{ kW}/\text{m}^2$ used as the power of thermal irradiation, the polyester was burnt in a more mild manner and, unlike the case at 35 and $50 \text{ kW}/\text{m}^2$, the second sharp peak (at 270 to $\sim 300 \text{ kW}/\text{m}^2$) was missing. In the case of fire-retarded GRPL samples, the rate of heat release did not fall past the first maximum (first HRR peak), i.e., there was no other HRR peak. This fact is due to the insulating effect of the carbon layer which stabilizes the release of the heat within the period of time that is related to the power of irradiation. The higher the power of irradiation, the more pronounced is the peak.

The data in Fig. 2 allow to see that, with fire-nonretarded GRPL, the average heat release rate rose from 160 to $210 \text{ kW}/\text{m}^2$ as the power of irradiation was raised. With fire-retarded GRPL, the rise was insignificant, 159 to $166 \text{ kW}/\text{m}^2$. The effect of the fire retardant is most eminent at the 300th second, unlike that at the 60th and the 180th second.

The maximum heat release rate (HRR_{max}) is seen (Fig. 3) to increase as the power of thermal irradiation is

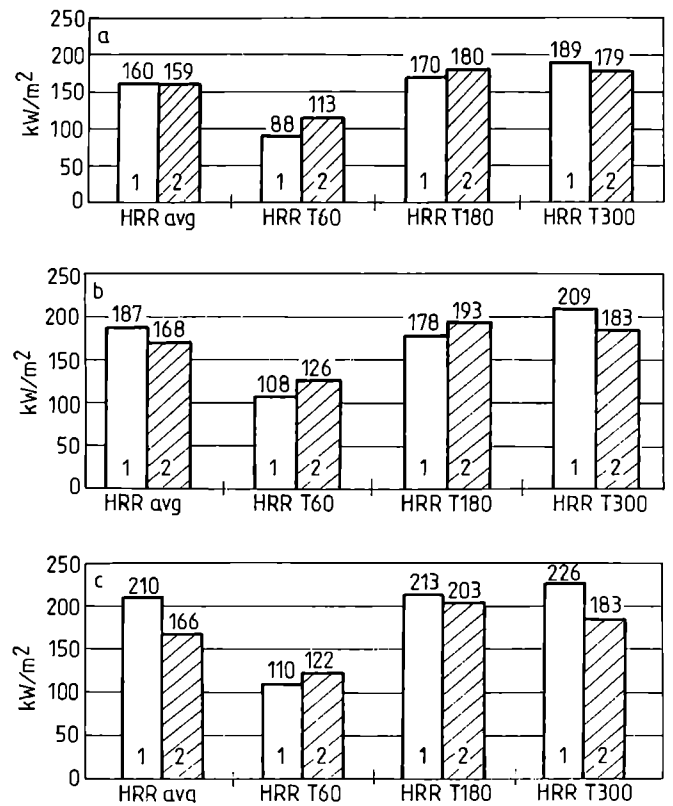

Fig. 2. The average HRR (HRR_{av}) and the HRR at the 60th, 180th and 300th second reckoned from ignition in relation to thermal irradiation power (for other designations see Fig. 1)

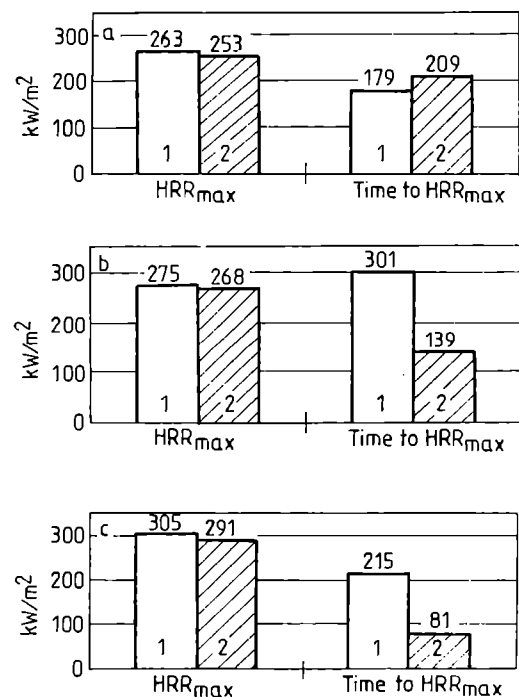

Fig. 3. The maximum HRR (HRR_{max}) and time required to attain HRR_{max} in relation to thermal irradiation power (for other designations see Fig. 1)

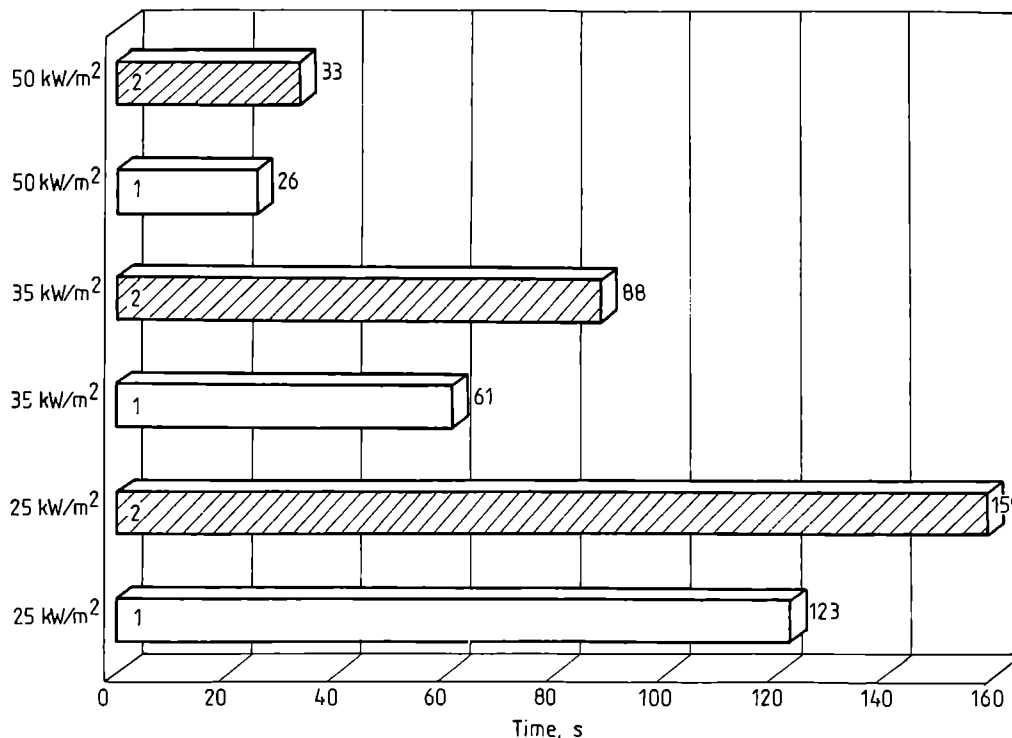

Fig. 4. Time required to ignite (τ_{ign}) in relation to thermal irradiation power: 1 — fire-retarded, 2 — fire-nonretarded GRPL

increased, regardless of the GRPL type. The fire retardant is seen to have reduced the HRR_{max} only slightly; on the other hand, the time elapsed to achieve HRR_{max} varies considerably. The presence of fire-retardants has affected the intensity of burning at the second stage of the fire. With fire-retarded GRPL, the intensity of the second stage of the fire has been reduced. When the power of thermal irradiation used was 35 or 50 kW/m^2 ,

the polyester burned more intensely and the time to reach HRR_{max} was longer, but within this period of time the fire-retarded polyester is seen to release heat at a reduced rate.

The time to ignite (τ_{ign}) is presented (Fig. 4) in relation to thermal irradiation power: the higher the power, the shorter the time to ignite the polyester. The fire retardant added to the polyester has invariably protracted

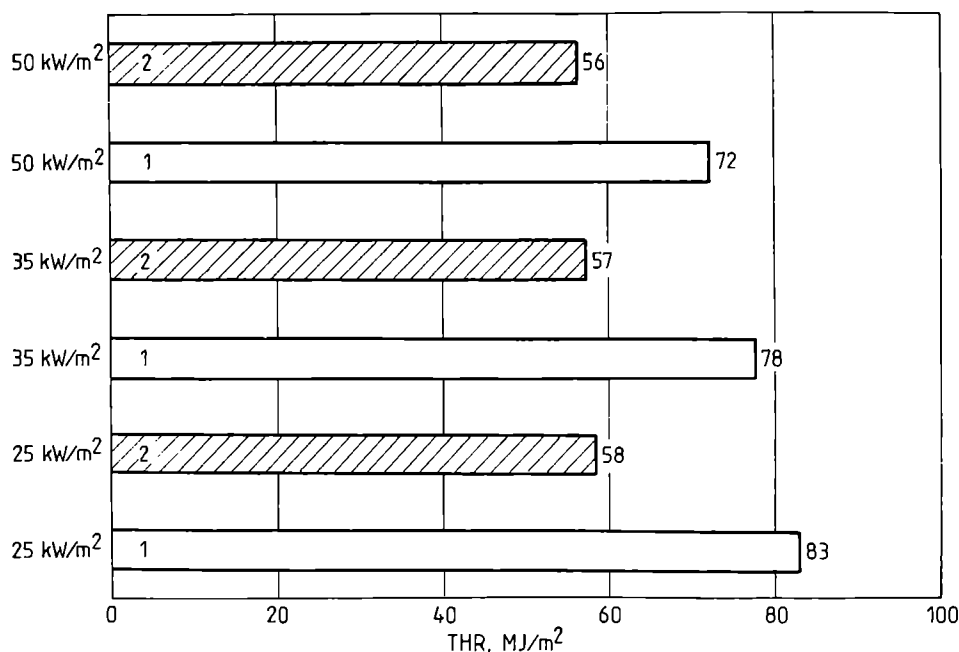

Fig. 5. Total heat released (THR) by: 1 — fire-retarded, 2 — fire-nonretarded GRPL in relation to thermal irradiation power

the time required to ignite the polyester. The higher is the difference between the powers of irradiation, the more pronounced is the effect of the fire retardant.

The total heat released (THR) by the polyester is expressed in MJ/m^2 . In the presence of a fire retardant, the polyester's THR is reduced (Fig. 5), *viz.*, 56–58 MJ/m^2 ; and there is no large difference between the heat released and the thermal irradiation. With fire-non-retarded GRPL, the THR is higher by 30 to 40%, *viz.*, 72–83 MJ/m^2 .

The specific extinction area (SEA) curves are presented (Fig. 6) in relation to thermal irradiation power. In the presence of a fire retardant, the amount of smoke is considerably smaller. The fire-retarded samples have invariably shown suppressed smoke evolution.

The difference is particularly well visible in the average extinction area (SEA_{av}) that has been measured over the entire duration of the test starting with the moment of ignition (Fig. 7). The fire-retarded GRPL show SEA_{av}

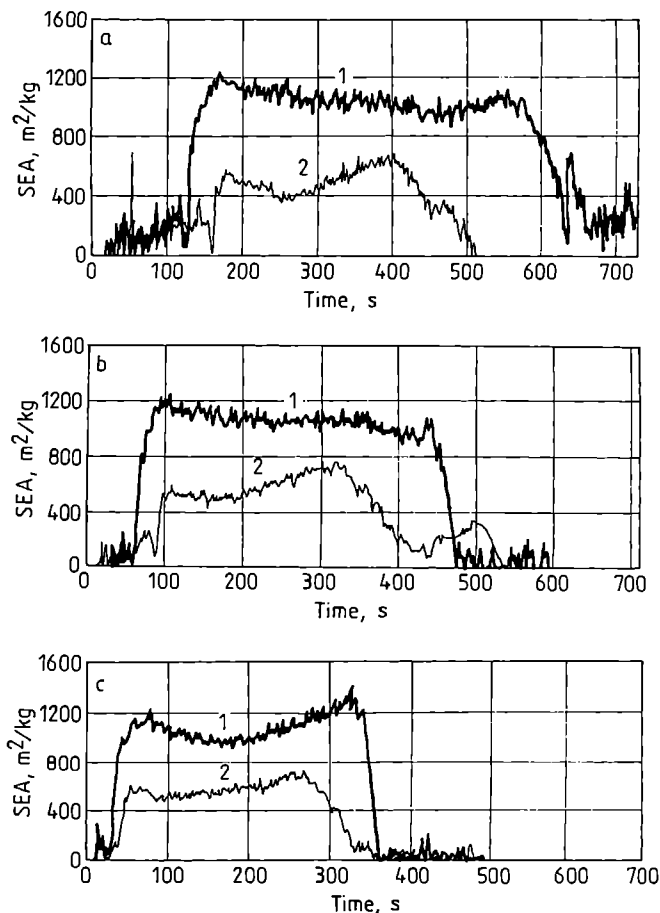

Fig. 6. The specific extinction area (SEA , m^2/kg) of: 1 — fire-nonretarded, 2 — fire-retarded GRPL, in relation to thermal irradiation power: a — 25, b — 35, c — 50 kW/m^2

Fig. 8. The mass loss rate (MLR) in relation to thermal irradiation power: a — 25, b — 35, c — 50 kW/m^2 (for other designations see Fig. 6)

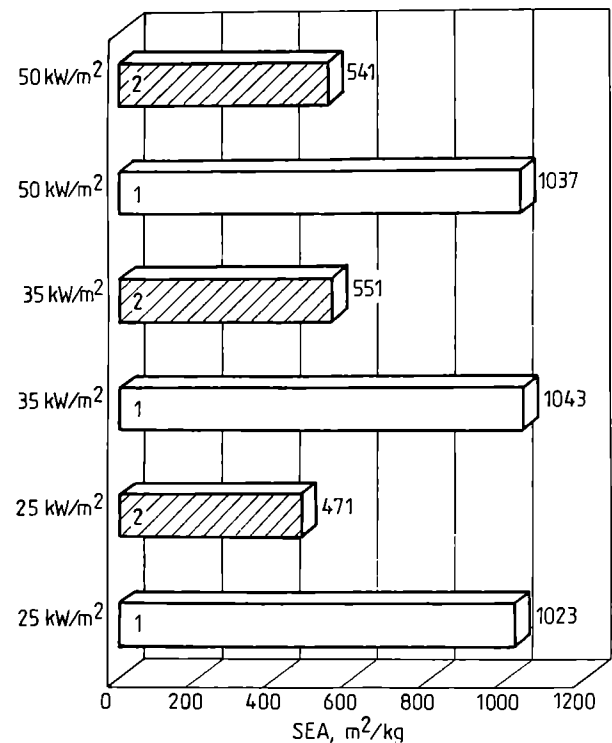
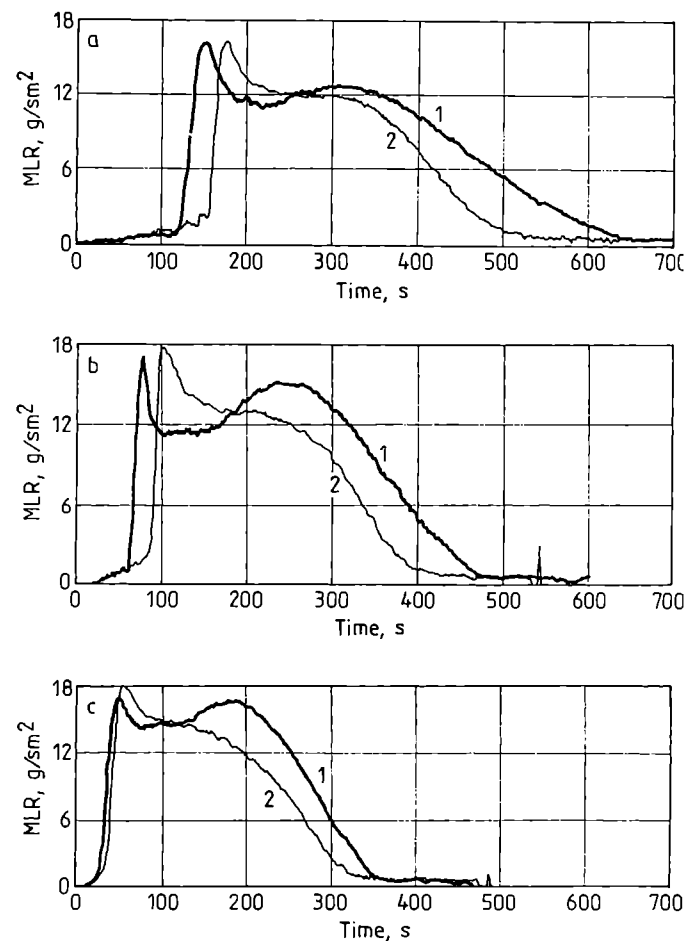

Fig. 7. The average extinction area (SEA_{av}) of: 1 — fire-nonretarded, 2 — fire-retarded GRPL, in relation to thermal irradiation power indicated on ordinates



of 471—541 m²/kg vs. the 1023—1037 m²/kg for the non-retarded GRPL.

The mass loss rate (MLR) curves, which are presented in relation to thermal radiation power (Fig. 8), are seen to follow courses analogous to those of the HRR curves (Fig. 1). Starting with the moment of ignition, the MLR curve rises to reach a certain level and then a maximum within a period of time that is related to the heat flux. The mass losses are largest when the entire polyester surface area exposed to thermal radiation is burning. In the presence of a fire-retardant, the second maximum in the MLR curve does not occur.

In the calorimetric tests, samples were weighed before and after the test. The total heat released was divided by the mass decrement to achieve the average heat of combustion. Most tests are discontinued soon after the flame has disappeared, and before oxidation of carbon becomes predominant. The effective heat of combustion is believed to be constant over this period of time.

CONCLUSIONS

The cone calorimeter allows to perform a complex analysis of all the stages of combustion and of smoke evolution during pyrolysis and to fully evaluate the level of fire-retardancy of GRPL materials based on fire-retarded polyesters as compared with the materials that have not been fire retarded.

The cone-calorimetric analysis performed for the GRPL showed the tin-zinc systems to be effective fire retardants for polyester resins, which reduce their flammability/combustibility level and essentially suppress smoke evolution essentially.

The GRPL examined are seen to be applicable as materials for transportation, construction and ship-building elements.

ACKNOWLEDGMENT

Dr. Maria Władyska-Przybylak of the Institute for Natural Fibers, Poznań, is cordially thanked for carrying out the cone-calorimetric measurements for the selected polyester compositions and for her cooperation in the interpretation of the data obtained.

REFERENCE

1. Kicko-Walczak E.: *Polimery* 1995, **40**, 665.
2. Cusack P. A., Monk A. W., Reynolds S. J.: *Fire and Materials* 1989, **14**, 23.
3. Babrauskas V.: *ibid.* 1994, **18**, 289.
4. Kicko-Walczak E.: *Polimery* 1992, **37**, 527.
5. Cusack P. A., Heer M. S., Monk A. W.: *Polym. Degrad. Stabil.* 1991, **32**, 17.
6. Weil E. D., Hirschler M. M., Patel N. G., Said M. M., Shaikr S.: *Fire and Materials* 1992, **16**, 159.
7. Władyska-Przybylak M., Helwig M., Kozłowski R.: Conf. Proc., XVIII Symp. "Protection of Wood" (in Polish), Jachranka, 4—16 September 1996, p. 112—116.
8. ISO Standard 5660-1 "Rate of heat release from building products (Cone calorimeter method)"
9. Mikkola E.: *J. Fire Sci.* 1990, **9**, 276.
10. Władyska-Przybylak M., Helwig M., Kozłowski R.: *Nat. Fibers (Włókna Naturalne)* 1996, **40**, 145.

Received 29 XI 1999.

Rapid Communications

Przypominamy P.T. Autorom, że prowadzimy w naszym czasopiśmie dział typu **Rapid Communications**. Publikujemy w nim, **wyłącznie w języku angielskim**, **krótkie** (3—4 strony maszynopisu i ewentualnie 2—3 rysunki lub tabele) **prace oryginalne**, którym gwarantujemy szybką ścieżkę druku, co oznacza, że pojawią się one w czasopiśmie w okresie nieprzekraczającym 5 miesięcy od chwili ich otrzymania przez redakcję.