

# Statistical inferences in material selection of a polymer matrix for natural fiber composites

M. Noryani<sup>1), 2), 3)</sup>, S.M. Sapuan<sup>1), 4), \*)</sup>, M.T. Mastura<sup>3), 5)</sup>, M.Y.M. Zuhri<sup>1)</sup>, E.S. Zainudin<sup>1)</sup>

DOI: [dx.doi.org/10.14314/polimery.2020.2.4](https://doi.org/10.14314/polimery.2020.2.4)

**Abstract:** In this paper, statistical inferences in material selection of polymer matrix for natural fiber composite are presented. Hypothesis testing and confidence interval were used to evaluate the suitability of the sample for use as a matrix in natural fiber reinforced composites. The screening process for material selection was carried out using a stepwise regression method. Then, the ranking process in material selection was conducted using an estimation of performance score (*PS*) for mechanical properties such as impact strength (*IS*), elongation at break (*E*) and tensile strength (*TS*). Ten types of polymer were involved in the study. The final selection revealed that polyamide (PA6), polyurethanes (PUR) and polypropylene (PP) are the potential candidates to manufacture hand-brake levers according to *IS*, *E* and *TS*, respectively. Here, it was found that the score for *Tp* (thermoplastic) is better than *Ts* (thermoset) in terms of *IS*. In contrast, the *Ts* offered a better score result than, *Tp*, with respect to *E* and *TS*. The results of statistical measurements using statistical modelling prove that the data analysis can be used as a part of the decision making in material selection.

**Keywords:** material selection, polymer matrix, stepwise regression, hypothesis testing, confidence interval.

## Wnioskowanie statystyczne w wyborze materiału osnowy polimerowej kompozytów z włóknami naturalnymi

**Streszczenie:** Opisano wnioskowanie statystyczne dotyczące wyboru materiału osnowy polimerowej kompozytu z włóknami naturalnymi. Testy hipotez statystycznych i przyjęte przedziały ufności służyły do oceny próbki pod względem przydatności do zastosowania w charakterze osnowy polimerowej w kompozycie wzmocnionym włóknem naturalnym. Selekcji materiałów dokonano przy użyciu metody regresji krokowej, następnie uszeregowano wybrane materiały z wykorzystaniem rankingu oceny (*PS*) właściwości mechanicznych, takich jak: udarność (*IS*), wydłużenie przy zerwaniu (*E*) i wytrzymałość na rozciąganie (*TS*). Wyselekcjonowano wstępnie 10 rodzajów polimerów zaliczanych do grup polimerów termoplastycznych (*Tp*) i termoutwardzalnych (*Ts*). Wnioskowanie statystyczne wykazało, że poliamid (PA6), poliuretany (PUR) i polipropylen (PP) są potencjalnie korzystnymi osnowami polimerowymi do wytwarzania dźwigni hamulca ręcznego. Stwierdzono, że polimery z grupy *Tp* wykazują lepszą udarność niż polimery z grupy *Ts*. Natomiast materiały *Ts* charakteryzują korzystniejsze wartości wydłużenia przy zerwaniu i wytrzymałości na rozciąganie niż ich odpowiedniki z grupy *Tp*. Wyniki przeprowadzonej analizy danych z zastosowaniem modelowania statystycznego dowodzą, że metoda ta może być pomocna przy wyborze materiału odpowiedniego do planowanej aplikacji.

**Słowa kluczowe:** wybór materiału, osnowa polimerowa, regresja krokowa, testowanie hipotez, przedział ufności.

<sup>1)</sup> Universiti Putra Malaysia, Department of Mechanical and Manufacturing Engineering, Advanced Engineering Materials and Composites Research Centre, 43400 UPM Serdang, Selangor, Malaysia.

<sup>2)</sup> Universiti Teknikal Malaysia Melaka, Faculty of Mechanical Engineering, Hang Tuah Jaya, 76100 Durian Tunggal, Melaka, Malaysia.

<sup>3)</sup> Universiti Teknikal Malaysia Melaka, Centre of Advanced Research on Energy, Hang Tuah Jaya, 76100 Durian Tunggal, Melaka, Malaysia.

<sup>4)</sup> Universiti Putra Malaysia, Institute of Tropical Forestry and Forest Products (INTROP), Laboratory of Biocomposite Technology, 43400 UPM Serdang, Selangor, Malaysia.

<sup>5)</sup> Universiti Teknikal Malaysia Melaka, Faculty of Mechanical and Manufacturing Engineering Technology, Hang Tuah Jaya, 76100 Durian Tunggal, Melaka, Malaysia.

\*) Author for correspondence: [sapuan@upm.edu.my](mailto:sapuan@upm.edu.my)

Recent studies discuss the ability of polymer composite to replace metal-based material, especially in the automotive and construction industries. Many researchers have put forward the capabilities, suitability and affordability of natural fibers as reinforcement agents for the polymer matrices. Natural fiber reinforced polymer composites had a good performance score with regard to their physical, mechanical and environmental properties when used in manufacturing automotive components such as clutch pedal, car front hood, buggy bonnet, bumper beam, car roof, brake lever and anti-roll bar [1–7]. As the materials are from natural sources, they can offer an economical outflow, lightweight, environmentally friendly materials and a biodegradable effect [5, 8–13]. However, the poor dimensional stability and high moisture absorption become a problem to these materials [14]. There are many treatments that can increase the strength connection between the natural fiber and polymer matrix [15–19] to produce a valuable polymer composite, especially in the automotive industry. Generally, thermoplastic (Tp) and thermoset (Ts) materials are the polymers used in many applications. Recently, there is a research trend in the automotive industry to produce lightweight vehicles to save energy consumption [20, 21]. Many studies have reported a good connection between natural fiber and polymer matrix based on the chemical composition as a better composite in automotive applications [22–24]. In addition, the combination also provides a balanced score for mechanical, thermal and electrical properties [25–27].

In general, the engineering plastics industry confirms the advantages of the product, such as it is lightweight, transparent, economical to produce, self-lubricates, has low water absorption and good resistance to corrosion, and design flexibility [28–30]. However, Tp and Ts have their own pros and cons. Fast processing, highly recyclable, high impact resistance, chemical resistance and eco-friendly manufacturing are the advantages of Tp. However, generally, Tp is more expansive and melts if heated. In contrast, Ts is more resistant to high temperature, has a highly flexible design, excellent aesthetic appearance, high level of dimensional stability and is cost effective. The disadvantages of Ts are that it is unrecyclable, difficult to surface finish, cannot be remolded or reshaped, and has a lower production rate due to its lengthy cure time [31–33]. In reality, there are variable and inconsistent conclusions about Tp and Ts in different applications. It is known that Tp is tougher than Ts because of the structure of the polymer itself. Chung [34] also claimed that the manufacturing time of Tp is shorter than that of Ts. Another study found that the mechanical properties, such as tensile strength, of Ts are better than those of Tp [35]. Although a number of investigations have reported interesting results for Tp and Ts, no study has examined their performance by using statistical inferences such as hypothesis testing and confidence interval.

In material selection, numerous multi-criteria decision-making (MCDM) tools can be used, such as Analytical

Hierarchy Process, Analytical Network Process, Multi-attribute Utility Theory, Preference Selection Index, Technique of Ranking Preferences by Similarity of the Ideal Solution and Quality Function Deployment. In practice, these tools have their own strengths and limitations on screening and ranking methods in the process to select the best material [36, 37]. The major problem in the conventional MCDM method is inconsistent judgement and preference subjectivity over the process selection. For example, there is no standard measurement for the weighting process in Analytical Hierarchy Process and Analytical Network Process [36, 38]. Some of the tools are only able to deal with qualitative data, which is also an issue in material selection [39]. The final decision is affected by the limitations of these tools. However, a recent study by Noryani *et al.* [40] introduced a novel statistical framework by using stepwise regression on the screening process. This approach is proven to finalize the best natural fiber in automotive application [41]. Statistical analyzes such as estimation, error analysis, hypothesis testing and confidence interval are the alternative measure-

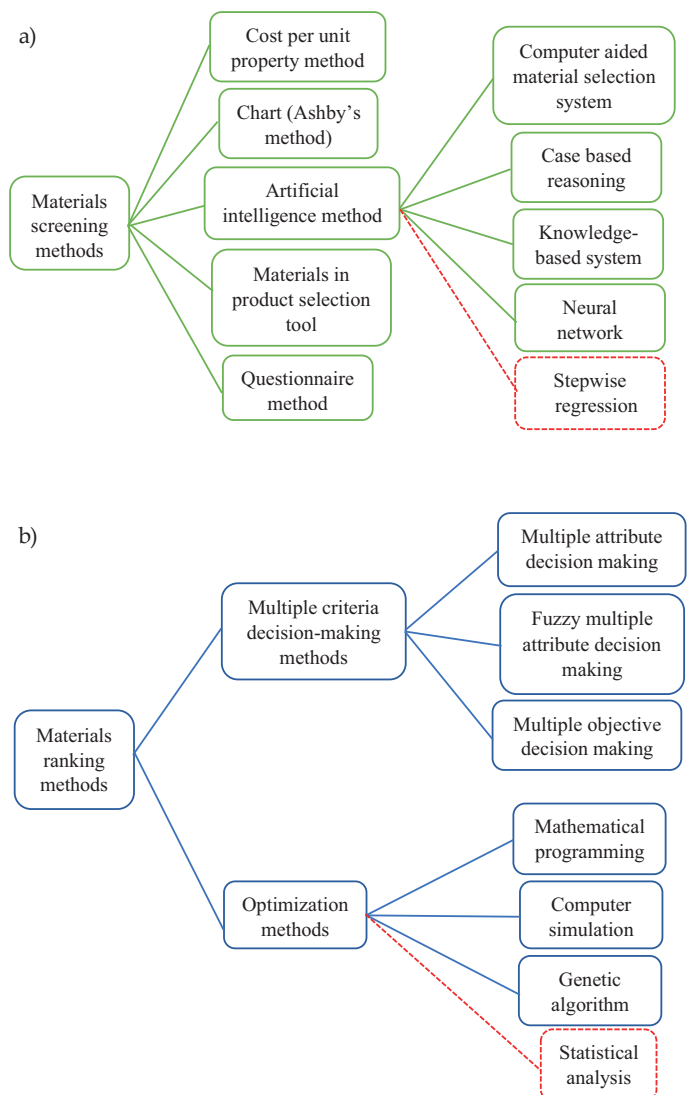

Fig. 1. Classification of: a) screening, b) ranking methods in material selection [37]

ments in the optimization method to rank the material's performance. In this study, the performance score ( $PS$ ) is measured by using equation (1), where  $x_i$  is the mechanical properties of the polymer matrix. This innovative contribution by using statistical inferences in material selection is shown in Fig. 1. To demonstrate the potential of this novel approach to screening and ranking methods as well as its suitability for material selection of the polymer matrix of an automotive component, the stepwise regression of polymer matrix data is studied and the significant statistical model for each polymer matrix is presented. Hypothesis testing and confidence interval are discussed as inferential analysis from the sample to estimate the  $PS$  using a constructed statistical model to make the final decision. This approach can give extra information and increase the decision maker's confidence to select the most potential candidate to manufacture a hand-brake lever for car parking, as in the case study.

$$PS = \sum_{i=1}^n x_i \quad i = 1, 2, \dots, n \quad (1)$$

## EXPERIMENTAL PART

The improvement using statistical inferential analysis in a statistical framework on previous studies is shown in Fig. 2.

### Material selection of Tp and Ts

The material selection process is an important stage in engineering applications, especially in product development for long-term success [42]. The engineer should select the most suitable material that performs well and can easily be commercialized. To avoid major loss during product design testing, the material selection process is the critical part of the manufacturing process [37]. Moreover, in this study, secondary data about the polymer matrix of thermoplastic and thermoset plastic from previous works is utilised, as shown in Table 1.

All the polymer in this study are hydrophobic polymers because this polymer used natural fiber as the reinforcement agent to the composite. The composite should be water resistant in automotive application to increase the strength of the properties. In this case, there are several processes used to prepare this type of polymer, injection molding, extrusion, pultrusion and hand lay-up are the common methods used in research area. This data set is used to select the most suitable polymer to manufacture a hand-brake lever, as shown in Fig. 3, for automotive industry application as the case study.

### Statistical measurement

Mean ( $\mu$ ) and standard deviation ( $\sigma$ ) are the normal statistical measurements used in previous studies [49–51]. Here, minimum, middle and maximum values

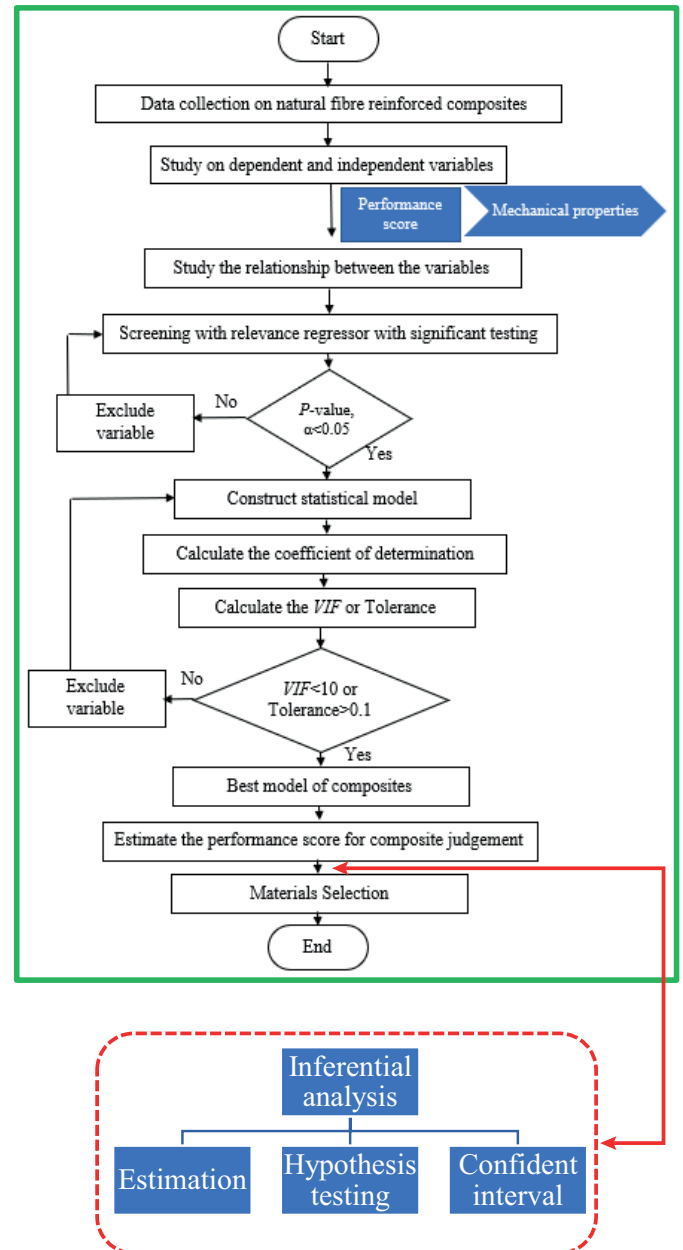

Fig. 2. Additional information for final decision on material selection

are used for mechanical properties of the Tp and Ts. The framework introduced previously by Noryani *et al.* [40] is used for the screening process, which involves another statistical measurement such as correlation ( $r$ ), determination of coefficient ( $R^2$ ), adjusted determination coefficient ( $AdjR^2$ ) or variance inflation factor ( $VIF$ ) to identify the best model of the polymer. Then, a comparison between the alternative polymers via an estimation process using statistical modelling is performed. Okayasu *et al.* [35] mentioned, estimation using statistical analysis can give a better result compare to the compound law.  $T$ -test statistics are used in hypothesis testing and confidence interval to confirm the successful inferential analysis to draw a conclusion about the performance of the Tp and Ts.

**Table 1.** The properties of thermoplastic and thermosetting [4, 17, 30, 43–46]

Polymer	Density ( <i>D</i> ) g/cm <sup>3</sup>	Young's modulus, ( <i>YM</i> ) GPa	Tensile strength, ( <i>TS</i> ) MPa	Elongation at break, ( <i>E</i> ) %	Impact strength, ( <i>IS</i> ) J/m <sup>2</sup>	Water absorption, ( <i>WA</i> ) 24 hours
PP	0.86	0.95	26.0	15.0	24.40	0.010
	0.89	1.36	33.7	43.0	85.05	0.010
	0.90	1.40	34.5	58.1	145.70	0.015
	0.91	1.60	36.0	73.2	206.35	0.02
	0.92	1.80	41.4	100.0	267.00	0.02
PS	1.04	3.14	25.0	12.0	1.0	0.03
	1.04	3.57	38.1	16.5	1.1	0.04
	1.05	4.00	51.1	21.0	1.0	0.06
	1.06	4.50	60.1	23.0	1.1	0.08
	1.06	5.00	69.0	25.0	1.0	0.10
HDPE	0.94	0.40	14.5	200	26.7	0.01
	0.95	0.76	22.0	745	288	0.01
	0.96	0.95	26.3	1000	548	0.02
	0.96	1.00	32.0	1120	808	0.02
	0.97	1.50	38.0	1290	1068	0.01
LDPE	0.91	0.06	7	100	854	0.015
	0.92	0.14	17	375	900	0.010
	0.93	0.22	40	650	930	0.015
	0.93	0.31	43	675	950	0.010
	0.94	0.38	78	700	1000	0.015
TPU	1.12	1.31	31.0	60	9.42	0.15
	1.15	1.50	38.8	182.5	16.80	0.16
	1.18	1.69	46.5	305	24.21	0.17
	1.21	1.88	54.3	427.5	31.60	0.18
	1.24	2.07	62.0	550	39.00	0.19
PA6	1.120	2.80	35	38.8	42.7	1.30
	1.125	2.85	39	59	72	1.43
	1.130	2.90	43	80	101	1.55
	1.135	2.95	61	100	130.5	1.68
	1.140	2.90	79	120	160	1.80
PR	1.2	2.0	40	2	15	0.10
	1.3	2.5	52.5	2.2	91	0.15
	1.4	3.3	65	2.4	167	0.20
	1.4	3.9	77.5	2.5	243	0.25
	1.5	4.5	90	2.6	320	0.30
VE	1.20	3.10	69	4.0	250	0.10
	1.25	3.27	72.5	4.7		0.05
	1.30	3.45	76	5.5		0.10
	1.35	3.62	79.5	6.2		0.15
	1.40	3.80	83	7.0		0.20
ER	1.10	3.0	35	1.0	n/a	0.10
	1.20	3.7	51	2.5		0.20
	1.25	4.5	67	3.5		0.25
	1.30	5.2	83	4.7		0.30
	1.40	6.0	100	6.0		0.40
PUR	1.04	4.09	14	3.0	n/a	0.10
	1.06	4.15	39	4.5		0.10
	1.09	4.20	52	6.0		0.15
	1.10	4.25	69	8.0		0.20
	1.13	4.30	75.8	10.0		0.20

PP: polypropylene, PS: polystyrene, HDPE: high-density polyethylene, LDPE: low-density polyethylene, TPU: thermoplastic polyurethane, PA6: polyamide, PR: polyester resin, VE: vinyl ester resin, ER: epoxy resin, PUR: polyurethanes.

### Hypothesis testing and confidence interval

Hypothesis testing is one of the inferential statistics that can be used to make a conclusion about the population based on a sample. In this study, hypothesis testing

is used to verify the performance of  $T_p$  and  $T_s$ . There are five command steps in hypothesis testing, which are: write the null and alternative hypothesis, perform the statistics testing, find the critical point and decide the region, finalise the decision making and, lastly, make a con-

a)



b)

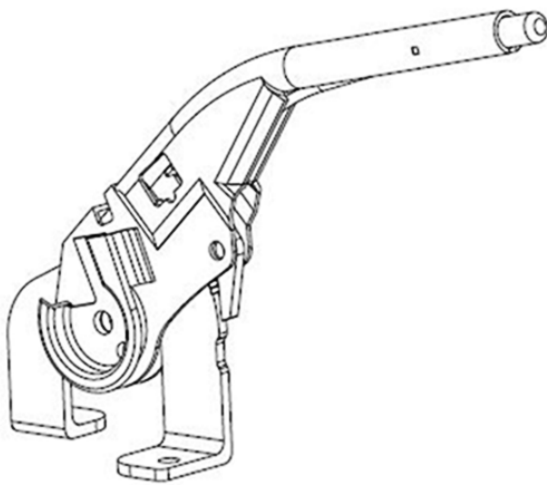

Fig. 3. Example of a hand-brake lever for: a) Suzuki Maruti, b) Proton Wira [47, 48]

clusion. All the calculations and conclusions in this study are based on  $\alpha = 0.05$  (5% standard error) significant value and 95% confidence interval. The one-tailed test is used where the hypothesis condition shows that  $T_p$  is better than  $T_s$ . Otherwise, the conclusion is that  $T_s$  perform better than  $T_p$ . Equations (2) to (4) are used to perform the hypothesis testing and confidence interval.

$$t = \frac{(\bar{x}_{T_p} - \bar{x}_{T_s}) - (\mu_{T_p} - \mu_{T_s})}{S_{\bar{x}_{T_p} - \bar{x}_{T_s}}} \quad (2)$$

$$\mu = (\bar{x}_{T_p} - \bar{x}_{T_s}) \pm t_{\alpha} S_{\bar{x}_{T_p} - \bar{x}_{T_s}} = \bar{x} \pm t_{\alpha} S_p \sqrt{\frac{1}{n_{T_p}} + \frac{1}{n_{T_s}}} \quad (3)$$

$$S_p = \sqrt{\frac{(n_{T_p} - 1)S_{T_p}^2 + (n_{T_s} - 1)S_{T_s}^2}{n_{T_p} + n_{T_s} - 2}} \quad (4)$$

where:  $\bar{x}_{T_p}$  – sample mean of  $T_p$  properties,  $\bar{x}_{T_s}$  – sample mean of  $T_s$  properties,  $\mu_{T_p}$  – population mean of  $T_p$  properties,  $\mu_{T_s}$  – population mean of  $T_s$  properties,  $S_{T_p}$  – standard deviation of  $T_p$ ,  $S_{T_s}$  – standard deviation of  $T_s$ ,  $S_p$  – pooled standard deviation for two samples,  $n_{T_p}$  – number of samples for  $T_p$ ,  $n_{T_s}$  – number of samples for  $T_s$ .

## RESULTS AND DISCUSSION

### Best model of polymer matrix using stepwise regression

Table 2 shows the best statistical model with significant mechanical properties with an excellent  $AdjR^2$  that described the variation of  $PS$ . This variation is explained by the significant mechanical properties. For example, the third model proposed by stepwise regression for PP mentioned that 99.9% of the variation of  $PS$  is explained by  $IS$ ,  $E$  and  $TS$ . This new approach was proposed in a previous study by Noryani *et al.* [40] to select the natural fiber composite. Another previous study reported significant tensile and flexural properties of a kenaf reinforced polypropylene composite using stepwise regression [52]. In this paper, the only significant mechanical property for thermosetting PR was  $WA$ , while the other mechanical properties did not contribute to the model for estimation purposes. Each polymer has its own significant mechanical properties. For estimation purposes, the most significant mechanical properties equation of the polymer where  $IS$ ,  $E$  and  $TS$  are chosen to be compared in the selection process. For example,  $IS$  is the significant mechanical property for PP, HDPE, LDPE and PA6. Therefore, this model is used to estimate the  $PS$  by substituting the product design specification of  $IS$  in manufacturing the hand-brake lever. The process is also applied for  $E$  and  $TS$  for the alternative polymer. The quality of the material's interface strength is evaluated by using an estimation process through the statistical model [53].

### Material selection based on performance of mechanical properties

$IS$ ,  $E$  and  $TS$  are the most significant mechanical properties in the polymer model. Here, the product design specification for manufacturing a hand-brake lever of  $IS$ ,  $E$  and  $TS$  is referred [43, 48, 54]. Selection of the materials should be consistent with the industry declaration on product design specification [38]. One of the materials used to manufacture the hand-brake lever is structural steel S235 [48]. The properties of S235 for  $IS$ ,  $E$  and  $TS$  are 27 J/m<sup>2</sup>, 25% and 460 MPa, respectively. Figures 4, 5 and 6 show the  $PS$  score according to  $IS$ ,  $E$  and  $TS$ . From the result, the PA6 is the best material to manufacture the hand-brake lever, if the focus of the automotive industry for the component is on  $IS$ . Surprisingly, PP, HDPE and LDPE only score around 26 to 27 of  $PS$  compared to PA6, which scored 61.61. Based on Fig. 5, there are six polymers involved in estimation on  $PS$  according to elongation at break of that material. This score can show the capability of a material to maintain its shape without crack formation. Both thermoset plastics, which are PUR (31.12) and ER (29.28), score the highest for  $PS$  compared to the other thermoplastic. In Fig. 6, the thermoplastic materials such as PP (512.48), PS (509.57) and HDPE (501.48) perform better on  $PS$  (according to  $TS$ ) com-

**Table 2. The best model with significant mechanical properties using stepwise regression**

Polymer	Model	Mechanical properties	$R^2$	$AdjR^2$	Standard error	$P$ -value	Equation
PP	1	IS	0.999	0.998	6.625	0.000	$y = 37.96 + 1.388 IS$
	2	IS, E	1.0	0.999	0.701	0.000	$y = 23.658 + 0.905 IS + 1.465 E$
	3	IS, E, TS	1.0	0.999	0.034	0.000	$y = -0.8798 + 1.009 IS + 0.965 E + 1.116 TS$
PS	1	TS	1.0	0.999	0.512	0.000	$y = 9.04 + 0.1342 TS$
	2	TS, E	1.0	0.999	0.074	0.000	$y = 4.945 + 1.097 TS + 0.822 E$
HDPE	1	TS	0.992	0.984	120.691	0.001	$y = -987.805 + 91.679 TS$
	2	TS, E	0.999	0.999	39.516	0.001	$y = -695.109 + 51.609 TS + 0.886 E$
	3	TS, E, IS	1.0	0.999	0.175	0.000	$y = 0.072 + 1.09 TS + E + 0.999 IS$
LDPE	1	E	0.994	0.988	42.023	0.001	$y = 823.594 + 1.283 E$
	2	E, IS	1.0	0.999	7.182	0.000	$y = -515.742 + 0.973 E + 1.612 IS$
	3	E, IS, TS	1.0	0.999	0.040	0.000	$y = -0.973 + E + 1.002 IS + TS$
TPU	1	WA	1.0	0.999	0.007	0.000	$y = -1965.146 + 13787.6 W$
PA6	1	IS	0.998	0.997	6.307	0.000	$y = 27.683 + 2.075 IS$
	2	IS, TS	1.0	0.999	0.302	0.000	$y = 15.114 + 1.722 IS + 0.94 TS$
PR	1	WA	1.0	0.999	0.086	0.000	$y = 18.49 + 268.2 W$
VE	1	YM	1.0	0.999	0.040	0.000	$y = -2.411 + 25.742 YM$
ER	1	TS	1.0	0.999	0.140	0.000	$y = 0.767 + 1.13 TS$
	2	TS, E	1.0	0.999	0.042	0.000	$y = 2.402 + 1.049 TS + 1.075 E$
PUR	1	TS	1.0	0.999	0.840	0.000	$y = 5.981 + 1.115 TS$
	2	TS, E	1.0	0.999	0.023	0.000	$y = 5.069 + 1.002 TS + 1.042 E$

pared to the thermoset plastics. It is also noted that PA6 (447.51) scores the lowest  $PS$  on this mechanical property. This is similar to results found by Al-Oqla and Sapuan [10], where PP offered a better result for use in natural fiber reinforced composite under uncertain environments. In contrast, Mansor *et al.* [4] suggested that PP is the second candidate to be used for a hand-brake lever when using the analytic hierarchy process. The variation on the estimation of  $PS$  is represented by the error bar plotted in Fig. 4, Fig. 5 and Fig. 6. It indicates the uncertainty in the measured approximation values. In a recent study, the error bar was an

informative tool to show the goodness of fit or dispersion of the data set [55, 56]. In detail, statistical testing such as hypothesis testing, confidence interval and  $t$ -test should be performed to draw the final conclusion.

#### Statistical inference on mechanical properties of $T_p$ and $T_s$

In this section, hypothesis testing is used as additional information to support the final decision making based on the earlier section where hypothesis testing can con-

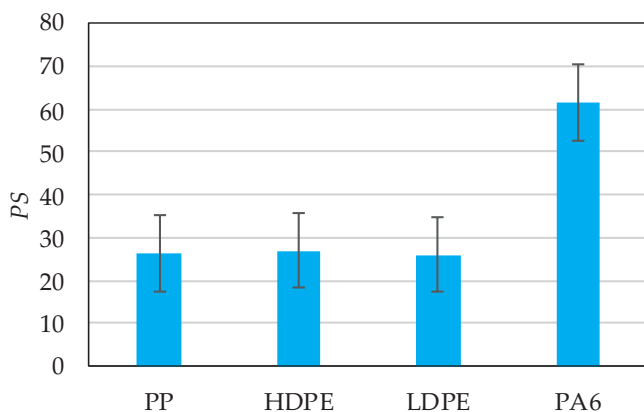

Fig. 4. The estimation of  $PS$  for the alternatives with regard to impact strength (IS)

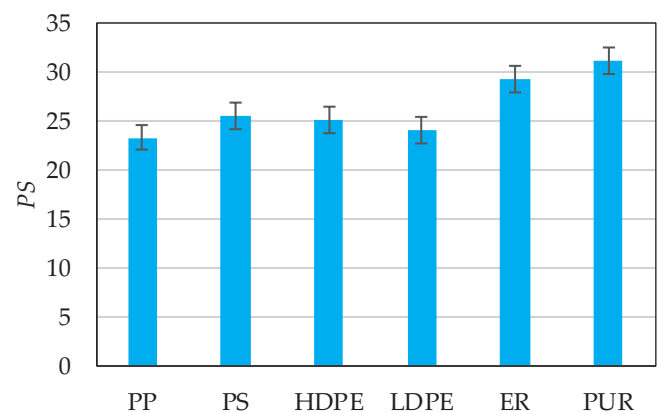

Fig. 5. The estimation of  $PS$  for the alternatives with regard to elongation at break (E)

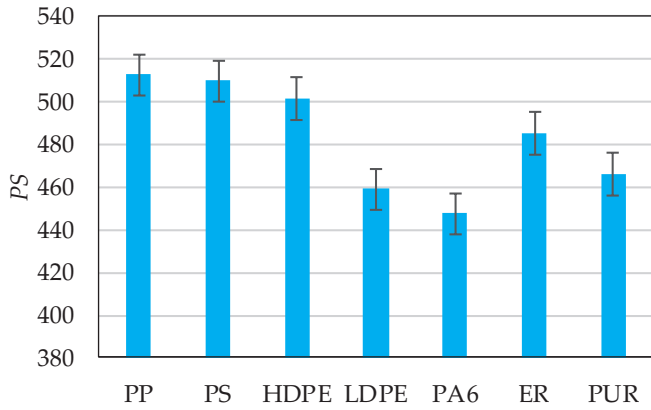

Fig. 6. The estimation of PS for the alternatives with regard to tensile strength (TS)

firm the validity of prediction by using an appropriate sample to draw a conclusion in this study. Moreover, confidence interval states the accepted range with 95% confident level on mechanical properties involved in this study. The hypothesis testing and confidence interval are performed for three selected mechanical properties, impact strength (IS), elongation at break (E) and tensile strength (TS). Table 3 shows the mean ( $\bar{x}$ ), sample standard deviation (s) and number of samples (n) for thermoplastic and thermoset plastic.

**Hypothesis testing**

Based on the result shown in Table 4, it can be concluded that Tp offers better IS value than Ts, due to insufficient evidence to reject  $H_0$ . Total energy absorbed by the material before it cracks or fails indicated the meaning of IS [57]. As the result, Tp has a higher IS compared to Ts. In this case, Tp has better ability to absorb the energy during the material’s failure. This finding is con-

**T a b l e 3. Statistical measurement of polymer for IS, E and TS**

Polymer	Statistical measurement	IS	E	TS
Thermoplastic, Tp	$\bar{x}_{Tp}$	291.121	305.486	40.736
	$s_{Tp}$	378.193	367.019	17.589
	n	29	29	29
Thermoset, Ts	$\bar{x}_{Ts}$	167.2	4.415	64.54
	$s_{Ts}$	120.483	2.299	21.167
	n	20	5	20

sistent with the finding in previous section: IS obtained insignificant mechanical properties in statistical modeling for Ts candidates. There are no Ts candidates plotted in Fig. 5, although the hypothesis testing for E concluded that the E of Ts is better than that of Tp. Based on calculated t-test (1.811), the value fall in the critical region and over the critical point (1.697), as confirmed by tabulated t-test with standard error ( $\alpha = 0.05$ ) and degree of freedom ( $df = n_{Tp} + n_{Ts} - 2$ ). At this stage, the evidence to reject  $H_0$  for E hypothesis testing is sufficient. Similarly, the TS for Ts is better than that for Tp. In other words, Ts is tougher and stronger than Tp. This is due to the natural behavior of this polymer, which has a strongly crosslinked molecular structure compared to the linear structure of Tp [34, 58]. Moreover, this polymer has not melted, and so the shape of items made from it would not change if heated. Similar to Okayasu *et al.*[35], the tensile strength of epoxy was found to be twice as good as the other thermoplastics such as PA6 and poly(phenylene sulphide) (PPS) for carbon fiber reinforced polymer. Sivakumar *et al.* [45] found that the tensile strength and modulus of Ts-based material is higher than Tp-based material for a hybrid composite. In general, the mean score of TS for Ts is higher compared to that of Tp, 64.54 and 40.74, as shown in Table 4.

**T a b l e 4. Hypothesis testing between thermoplastic and thermoset plastic according to mechanical properties**

Mechanical properties	Impact strength	Elongation at break	Tensile strength
1. Hypothesis		$H_0 : \mu_{Tp} \geq \mu_{Ts}$ $H_1 : \mu_{Tp} < \mu_{Ts}$	
2. Test statistics	$t = \frac{(291.121 - 167.2) - 0}{87.7272}$ $t = 1.413$	$t = \frac{(305.486 - 4.415) - 0}{166.252}$ $t = 1.811$	$t = \frac{(40.736 - 64.54) - 0}{5.557}$ $t = -4.284$
3. Critical region	Critical point: $t_{\alpha, df/(nTp + nTs - 2)} = t_{0.05, 47} = 1.68$ 	Critical point: $t_{\alpha, df/(nTp + nTs - 2)} = t_{0.05, 32} = 1.697$ 	Critical point: $t_{\alpha, df/(nTp + nTs - 2)} = t_{0.05, 47} = 1.684$ 
4. Decision making	Reject $H_0$ if t-statistic fall in the region		
	Do not reject $H_0$	Reject $H_0$	Reject $H_0$
5. Conclusion	IS of Tp is better than Ts	E of Ts is better than Tp	TS of Ts is better than Tp

### Confidence interval

Generally, confidence interval gives a range value of *IS*, *E* and *TS* from the data collected for *Tp* and *Ts*. Here, there is a 95% confidence interval that the value of *IS*, *E* and *TS* of *Tp* and *Ts* is between (-23.81, 271.65), (18.94, 583.20) and (14.45, 33.16), respectively. By using Eq. (3) and information from Table 3, detailed calculation is shown in Table 5.

**Table 5. Confidence interval of mechanical properties for polymer**

Mechanical properties	95% confidence interval
<i>IS</i>	$\mu_{IS} = (291.121 - 167.2) \pm 1.684(301.79) \sqrt{\frac{1}{29} + \frac{1}{20}} =$ $= 123.921 \pm 147.732 = (-23.811, 271.653)$
<i>E</i>	$\mu_E = (305.486 - 4.415) \pm 1.697(343.316) \sqrt{\frac{1}{29} + \frac{1}{5}} =$ $= 301.071 \pm 282.129 = (18.941, 583.200)$
<i>TS</i>	$\mu_{TS} = (64.54 - 40.736) \pm 1.684(19.117) \sqrt{\frac{1}{29} + \frac{1}{20}} =$ $= 23.804 \pm 9.358 = (14.446, 33.162)$

Overall, 95% of the general impact strength of the polymer is distributed between -23.811 J/m<sup>2</sup> and 271.653 J/m<sup>2</sup>. In this case, zero impact to 271.653 J/m<sup>2</sup> are the range of the impact strength of polymer are distributed. For elongation at break, the distribution is between 18.941% and 583.200% and, lastly, with the same confidence interval, which is 95% of the tensile strength, the distribution is between 14.446 MPa and 33.162 MPa.

### CONCLUSIONS

The evaluation of mechanical properties for 10 types of polymer in material selection by using statistical modelling was successfully achieved in this work. Additional information from statistical measurement such as estimation, hypothesis testing and confidence interval in this study was used to demonstrate the material's performance effectively for each candidate throughout the polymer selection process. It can be concluded here that proper selection of polymers is dependent on mechanical properties that influence the statistical modelling for estimation, hypothesis testing and confidence interval. This work can act as a guideline for the selection of the most suitable polymer candidate for an engineering application. The results showed that:

– hypothesis testing and confidence interval results achieved a good agreement with the theory of thermoset and thermoplastic materials and this led to the final decision making on material selection;

– impact strength, elongation at break and tensile strength of the polymer were the three most important mechanical properties shown by the statistical modelling;

– the most suitable candidates to manufacture the hand-brake lever are PA6 if based on impact strength, PUR on elongation at break and PP on tensile strength;

– thermoset plastic offers better results than thermoplastic for tensile strength and elongation at break, whereas thermoplastic exhibits better impact strength than thermoset.

### ACKNOWLEDGMENTS

The authors would like to thank Universiti Putra Malaysia for the opportunity to conduct this study as well as Universiti Teknikal Malaysia Melaka and the Ministry of Education of Malaysia for providing the scholarship award and grant scheme Hi-COE (6369107) to the principal author in this project.

### REFERENCES

- [1] Furtado S.C.R., Araújo A.L., Silva A. *et al.*: *International Journal of Automotive Composites* **2014**, 1, 18. <http://dx.doi.org/10.1504/IJAUTO.2014.064112>
- [2] Hambali A., Sapuan S.M., Ismail N., Nukman Y.: *Journal of Central South University of Technology* **2010**, 17, 244. <http://dx.doi.org/10.1007/s11771-010-0038-y>
- [3] Ishak N.M., Malingam S.D., Mansor M.R.: *International Journal of Materials and Product Technology* **2016**, 53, 267. <http://dx.doi.org/10.1504/IJMPT.2016.079205>
- [4] Mansor M.R., Hambali A., Azaman M.D. *et al.*: *International Symposium on the Analytic Hierarchy Process* **2013**, pp. 1–8. <http://dx.doi.org/10.13033/isahpy2013.053>
- [5] Mastura M.T., Sapuan S.M., Mansor M.R., Nuraini A.A.: *The International Journal of Advanced Manufacturing Technology* **2017**, 89, 2203. <http://dx.doi.org/10.1007/s00170-016-9217-9>
- [6] Mayyas A., Shen Q., Mayyas A. *et al.*: *Materials and Design* **2011**, 32, 2771. <http://dx.doi.org/10.1016/j.matdes.2011.01.001>
- [7] Sapuan S.M.: *Assembly Automation* **2005**, 25, 146. <http://dx.doi.org/10.1108/01445150510590514>
- [8] Aghajani Mir M., Taherei G.P., Sulaiman N.M.N. *et al.*: *Journal of Environmental Management* **2016**, 166, 109. <http://dx.doi.org/10.1016/j.jenvman.2015.09.028>
- [9] Al-Oqla F.M., Sapuan S.M., Ishak M.R., Nuraini A.A.: *Journal of Composite Materials* **2015**, 50, 543. <http://dx.doi.org/10.1177/0021998315577233>
- [10] AL-Oqla F.M., Sapuan S.M.: *The Journal of The Minerals, Metals & Materials Society* **2015**, 67, 2450. <http://dx.doi.org/10.1007/s11837-015-1548-8>
- [11] Altay L., Atagur M., Akyuz O. *et al.*: *Polymer Composites* **2017**, 39, 1.
- [12] Sahari J., Sapuan S.M., Zainudin E.S., Maleque M.A.: *Materials and Design* **2013**, 49, 285. <http://dx.doi.org/10.1016/j.matdes.2013.01.048>



- [13] Verrey J., Wakeman M.D., Michaud V., Månson J.A.E.: *Composites Part A: Applied Science and Manufacturing* **2006**, 37, 9.  
<http://dx.doi.org/10.1016/j.compositesa.2005.05.048>
- [14] Jumaidin R., Sapuan S.M., Jawaid M., Ishak M.R.: *International Journal of Biological Macromolecules* **2017**, 97, 606.  
<http://dx.doi.org/10.1016/j.ijbiomac.2017.01.079>
- [15] Bienias B., Michalski W., Wagner L.: *Polimery* **2019**, 64, 417.  
<http://dx.doi.org/10.14314/polimery.2019.6.4>
- [16] Amel B.A., Paridah M.T., Sudin R. et al.: *Industrial Crops and Products* **2013**, 46, 117.  
<http://dx.doi.org/10.1016/j.indcrop.2012.12.015>
- [17] Gurunathan T., Mohanty S., Nayak S.K.: *Composites Part A: Applied Science and Manufacturing* **2015**, 77, 1.  
<http://dx.doi.org/10.1016/j.compositesa.2015.06.007>
- [18] Zhao Y.W., Gu Y.Z., Huang P.: *Polymer Composites* **2017**, 39, 1.
- [19] Ilyas R.A., Sapuan S.M., Ishak M.R., Zainudin E.S.: *Carbohydrate Polymers* **2018**, 202, 186.  
<http://dx.doi.org/10.1016/j.carbpol.2018.09.002>
- [20] Calado E.A., Leite M., Silva A.: *Journal of Cleaner Production* **2018**, 186, 113.  
<http://dx.doi.org/10.1016/j.jclepro.2018.02.048>
- [21] Lyu M.Y., Choi T.G.: *International Journal of Precision Engineering and Manufacturing* **2015**, 16, 213.  
<http://dx.doi.org/10.1007/s12541-015-0029-x>
- [22] Azammi A.M.N., Sapuan S.M., Ishak M.R., Sultan M.T.H.: *Fibers and Polymers* **2018**, 19, 446.
- [23] Radzi A.M., Sapuan S.M., Jawaid M., Mansor M.R.: *Fibers and Polymers* **2017**, 18, 1353.  
<http://dx.doi.org/10.1007/s12221-017-7311-8>
- [24] Väisänen T., Das O., Tomppo L.: *Journal of Cleaner Production* **2017**, 149, 582.
- [25] Ilyas R.A., Sapuan S.M., Ishak M.R., Zainudin E.S.: *International Journal of Biological Macromolecules* **2019**, 123, 379.
- [26] Punyamurthy R., Sampathkumar D.: *International Journal of Sciences: Basic and Applied Research* **2014**, 18, 305.
- [27] Rajesh M., Pitchaimani J., Rajini N.: *Procedia Engineering* **2016**, 144, 1055.  
<http://dx.doi.org/10.1016/j.proeng.2016.05.056>
- [28] Hufenbach W., Gude M., Geller S., Czulak A.: *Polimery* **2013**, 58, 473.  
<http://dx.doi.org/10.14314/polimery.2013.473>
- [29] Salasinska K., Polka M., Gloc M., Ryszkowska J.: *Polimery* **2016**, 61, 255.  
<http://dx.doi.org/10.14314/polimery.2016.255>
- [30] Peters E.N.: "Thermoplastics, Thermosets, and Elastomers – Descriptions and Properties" in "Mechanical Engineers' Handbook" 4th ed. (Ed. Kutz M.), John Wiley & Sons Inc, Selkirk, New York 2015.
- [31] Abishera R., Velmurugan R., Nagendra Gopal K.V.: *Polymer Engineering Science* **2018**, 58, 189.  
<http://dx.doi.org/10.1002/pen.24861>
- [32] Singh A.K., Panda B.P., Mohanty S. et al.: *Polymer-Plastics Technology and Engineering* **2018**, 57, 903.  
<http://dx.doi.org/10.1080/03602559.2017.1354253>
- [33] Tatsuno D., Yoneyama T., Kawamoto K., Okamoto M.: *Polymer Composites* **2016**, 39, 2571.  
<http://dx.doi.org/10.1002/pc.24242>
- [34] Chung D.D.L.: *Materials Science and Engineering: R: Reports* **2017**, 113, 1.  
<http://dx.doi.org/10.1016/j.msere.2017.01.002>
- [35] Okayasu M., Tsuchiya Y., Arai H.: *Journal of Materials Science Research* **2018**, 7, 12.  
<http://dx.doi.org/10.5539/jmsr.v7n3p12>
- [36] Velasquez M., Hester P.T.: *International Journal of Operations Research* **2013**, 10, 56.
- [37] Shah D.U.: *Materials and Design* **2014**, 62, 21.  
<http://dx.doi.org/10.1016/j.matdes.2014.05.002>
- [38] Ahmed Ali B.A., Sapuan S.M., Zainudin E.S., Othman M.: *Journal of Cleaner Production* **2015**, 107, 557.  
<http://dx.doi.org/10.1016/j.jclepro.2015.05.084>
- [39] Das A., Kumar A.: *Journal of Mechanical and Civil Engineering* **2015**, 12, 82.
- [40] Noryani M., Sapuan S.M., Mastura M.T. et al.: *Fibers and Polymers* **2018**, 19, 1039.  
<http://dx.doi.org/10.1007/s12221-018-8113-3>
- [41] Noryani M., Sapuan S.M., Mastura M.T. et al.: *Journal of Materials Research and Technology* **2019**, 8, 2865.  
<http://dx.doi.org/10.1016/j.jmrt.2019.02.019>
- [42] Yousefpour M., Rahimi A.: *Materials and Design* **2014**, 54, 382.  
<http://dx.doi.org/10.1016/j.matdes.2013.08.017>
- [43] "Granta Design, CES Edupack" 2013.
- [44] Mastura M.T., Sapuan S.M., Mansor M.R., Nuraini A.A.: *International Journal of Precision Engineering and Manufacturing-Green Technology* **2017**, 5, 111.  
<http://dx.doi.org/10.1007/s40684-018-0012-y>
- [45] Sivakumar D., Ng L.F., Lau S.M., Lim K.T.: *Journal of Polymer Environment* **2017**, 26, 499.  
<http://dx.doi.org/10.1007/s10924-017-0970-0>
- [46] Stirna U., Beverte I., Yakushin V., Cabulis U.: *Journal of Cellular Plastics* **2011**, 47, 337.  
<http://dx.doi.org/10.1177/0021955X11398381>
- [47] Mansor M.R., Sapuan S.M., Zainudin E.S. et al.: *Materials and Design* **2013**, 51, 484.  
<http://dx.doi.org/10.1016/j.matdes.2013.04.072>
- [48] Patel M.V., Sarawade S.S.: "Design and Weight Optimization of Parking Brake Lever" in 3<sup>rd</sup> International Conference on Emerging Trends in Engineering and Management Research, Pune, India, July 30, 2017, p. 367.
- [49] Fayazbakhsh K., Abedian A., Manshadi B.D., Khabbaz R.S.: *Materials and Design* **2009**, 30, 4396.  
<http://dx.doi.org/10.1016/j.matdes.2009.04.004>
- [50] Linul E., Marsavina L., Voiconi T., Sadowski T.: *Journal of Physics: Conference Series* **2013**, 451, 1.  
<http://dx.doi.org/10.1088/1742-6596/451/1/012002>
- [51] Van de Velde K., Kiekens P.: *Composite Structures* **2001**, 54, 355.

- [52] Noryani M., Sapuan S.M., Mastura M.T. *et al.*: "Stepwise regression for kenaf reinforced polypropylene composite" in 5<sup>th</sup> Mechanical Engineering Research Day 2018, Melaka, Malaysia, May 3, 2018, p. 48.
- [53] Peponi L., Biagiotti J., Torre L. *et al.*: *Polymer Composites* **2008**, 29, 313.  
<https://doi.org/10.1002/pc.20408>
- [54] Chung K.F., Chiew S.P., Lee H.Y.: "Selection of Equivalent Steel Materials to European Steel Materials Specifications", Hong Kong Constructional Metal Structures Association, Hong Kong 2015.
- [55] Priya I.I.M., Vinayagam B.K.: *International Journal of Polymer Science* **2018**, ID 8629894.  
<https://doi.org/10.1155/2018/8629894>
- [56] Selamat M.Z., Syazwan M., Tahir Z. *et al.*: "Effect of starch sizes particle as binder on short pineapple leaf fiber composite mechanical properties" in MATEC Web of Conferences **2018**, 150, 04008, MUCET 2017 Malaysia.  
<http://dx.doi.org/10.1051/mateconf/201815004008>
- [57] Nadlene R., Sapuan S.M., Jawaid M. *et al.*: *BioResources* **2016**, 11, 9325.
- [58] Sapuan S.M.: "Composite Materials" in "Composite Materials" 1st ed. (Ed. Sapuan S.M.), Butterworth-Heinemann: Elsevier Inc., 2017, pp. 57–93.  
<http://dx.doi.org/10.1016/B978-0-12-802507-9.00003-9>

Received 26 VI 2019.

Serdecznie zapraszamy pracowników uczelni, instytutów badawczych i przemysłu  
do udziału w

**XIV Konferencji Naukowo-Technicznej  
„Kierunki Modyfikacji i Zastosowań  
Tworzyw Polimerowych”**

połączonej z **XXII Warsztatami Profesorskimi**,

która odbędzie się w dniach 25–27 maja 2020 r.

w Centrum Postępu Technicznego SIMP w zamku w Rydzynie k. Leszna.

Celem spotkania jest prezentacja i dyskusja naukowa dotycząca przetwórstwa tworzyw polimerowych, ich modyfikacji, metod oceny właściwości oraz nowych zastosowań, a także możliwości współpracy z przemysłem. Wzorem spotkania w 2019 roku (*Polimery* **2019**, 10, 705), planowana jest szeroka dyskusja z udziałem przedstawicieli przemysłu na temat gospodarki tworzywami polimerowymi w obiegu zamkniętym.

**Przewodniczący konferencji:**

Prof. dr hab. inż. Tomasz Sterzyński

**Sprawy organizacyjne:**

Dr inż. Monika Knitter – [monika.knitter@put.poznan.pl](mailto:monika.knitter@put.poznan.pl), tel. 61 665-28-94

Dr inż. Monika Dobrzyńska-Mizera – [monika.dobrzynska-mizera@put.poznan.pl](mailto:monika.dobrzynska-mizera@put.poznan.pl), tel. 61 665-28-94

Biuro Organizacyjne: DIVISIA [www.divisia.pl](http://www.divisia.pl)

**[www.zts-rydzyna2020.divisia.pl](http://www.zts-rydzyna2020.divisia.pl)**